

**2015 - 2025
Ford Super Duty
6.7L Power Stroke
Diesel Trucks**
(with single alternator)



Ventech 

HeatStroke LHG
(Liquid Heat Generator)

INSTALLATION MANUAL
Ventech Kits 0400 & 0401

12/12/2024

IMPORTANT

Information About This Manual

From model year to model year, vehicle manufacturers often make changes to the configuration, castings, and accessories found under the hood and occasionally make changes within a model year. As this manual attempts to cover a range of model years for the supported vehicle, were we to try to document every difference that could impact the LHG installation, it would quickly reach unreasonable proportions.

For this reason, we have illustrated the LHG installation procedure on one representative model year with occasional notes and images from other years when the differences are critical.

While the manual may not exactly match your model, the basics always apply.

Regardless of model year, the mounting brackets, idler pulleys and LHG should fit cleanly and securely, and the belt sit properly on the idler pulleys **WITHOUT ANY MODIFICATION** on your part. If they do not, don't try to make them fit. Discontinue the installation and contact Ventech immediately.

Table of Contents

- 1. Kit Overview.....6**
 - 1.1 Kit Diagram 1 and Part Descriptions.....6
 - 1.2 Kit Diagram 2 and Part Descriptions 8
 - 1.3 Identification Sizing Table.....10
- 2. Tools We Used 12**
- 3. Before you begin 14**
 - 3.1 Best Practices14
 - 3.1.1 Fastener Torque14
 - 3.1.2 Use Threadlock – (LocTite)14
- 4. About the Ventech HeatStroke LHG 14**
- 5. Preparing for Installation..... 15**
 - 5.1 Complete the LHG Bracket Assembly.....19
- 6. Mechanical Installation24**
 - 6.1 Prepare and install the pulleys..... 24
 - 6.2 Prepare for LHG assembly installation..... 25
 - 6.2.1 Install the first Stud..... 25
 - 6.2.2 Install the SECOND of TWO Studs 26
 - 6.3 Move some wiring 27
 - 6.4 Install the LHG assembly..... 27
 - 6.5 Install the new belt 30
 - 6.6 Install the new hoses.....31
 - 6.6.1 Trim the supplied hoses31
 - 6.6.2 Disconnect & Reroute the OEM Hose.....31
 - 6.6.3 Prepare and connect the
output hose from the LHG..... 32
 - 6.6.4 Prepare and connect
the input hose to the LHG..... 33

6.7	Prepare and Install the LHG ECU	37
6.8	Install the wiring harness.....	38
6.8.1	Connect the LHG and ECU	38
6.8.2	Position & Secure the OATS.....	40
6.8.3	Connect the Wiring Harness to the OEM Firewall Pass Through Wires	41
6.9	Install the LHG switch in the cab.....	42
7.	Reconnect the batteries.....	47
7.1	Connect the LHG to power	47
8.	Secure the wiring harness	47
9.	Complete the installation	48
10.	Final Inspection	49
11.	Initial Start-up	50
11.1	Initial startup behavior	50
11.1.1	AIR PURGE	50
11.1.2	BURNISHING	50
11.2	The first start	50
11.3	Concluding the installation.....	50
	Appendix A: The LHG ECU (Digital Controller) Strategy	51
	Understanding the ECU LEDs during Normal Operation and as a Diagnostic Tool.....	51
	Appendix B: Dash Switch Location Template.....	55

1. Kit Overview

1.1 Kit Diagram 1 and Part Descriptions

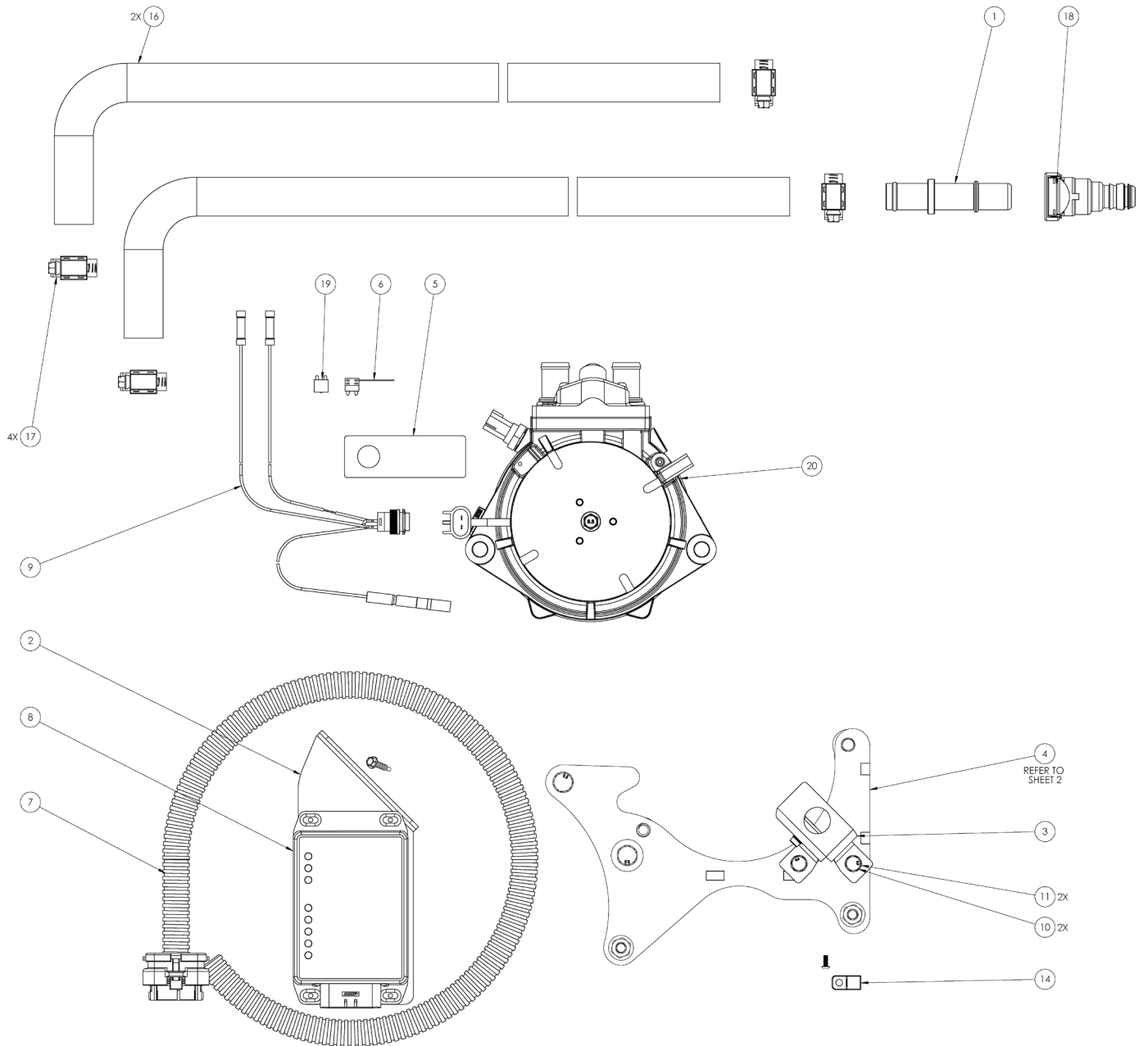

ITEM NO - Diagram 1	PART NUMBER	DESCRIPTION	QTY.
1	14-0555	ADAPTER, 3/4" J2044 (M) TO 3/4" HOSE BARB	1
2	14-0556	ECU BRACKET	1
3	140-0155	LHG ROTOR RPM BRACKET ASS'Y (STANDARD)	1
4	160-0002	HEATSTROKE WELDMENT (SEE PAGES 6-7)	1
5	13-0011	DECAL, CAB, "HEATSTROKE LHG", SWITCH	1
6	95-0060	FUSE TAP, ATR, 10A MAX	1
7	130-0049	DELUXE ECU HARNESS ASSY, DUAL RPM SENSOR	1
8	135-0041	ENHANCED DELUXE ECU, LIGHT/MEDIUM TRUCK	1
9	135-0042	SWITCH ASSEMBLY, W/ PIGTAIL, FORD SUPER DUTY	1
10	920-0241	M6-1.0 x 18 HEX HEAD BOLT - 8.8 - ZINC PLATED	2
11	925-0020	M6 LOCK WASHER	2
12	990-0001	NYLON TIE WRAPS (11") [NOT SHOWN]	10
13	990-0002	NYLON TIE WRAPS (8") [NOT SHOWN]	5
14	990-0004	4-WAY CABLE TIE MOUNT	1
15	990-0012	LOC-TITE (BLUE) [NOT SHOWN]	1
16	990-0045	3/4" HEATER HOSE W/ 90 DEG. ELBOW, 4" X 60"	2
17	990-0093	SAE #12 WORM DRIVE HOSE CLAMP	4
18	990-0216	ADAPTER, QUICK CONNECT, 3/4" J2044 (F) TO 3/4"	1
19	96-0034	ATR-5 AUTOMOTIVE ATR FUSE, 5A, 32VDC	1
20	LHG700	HEATSTROKE LHG	1

1.2 Kit Diagram 2 and Part Descriptions

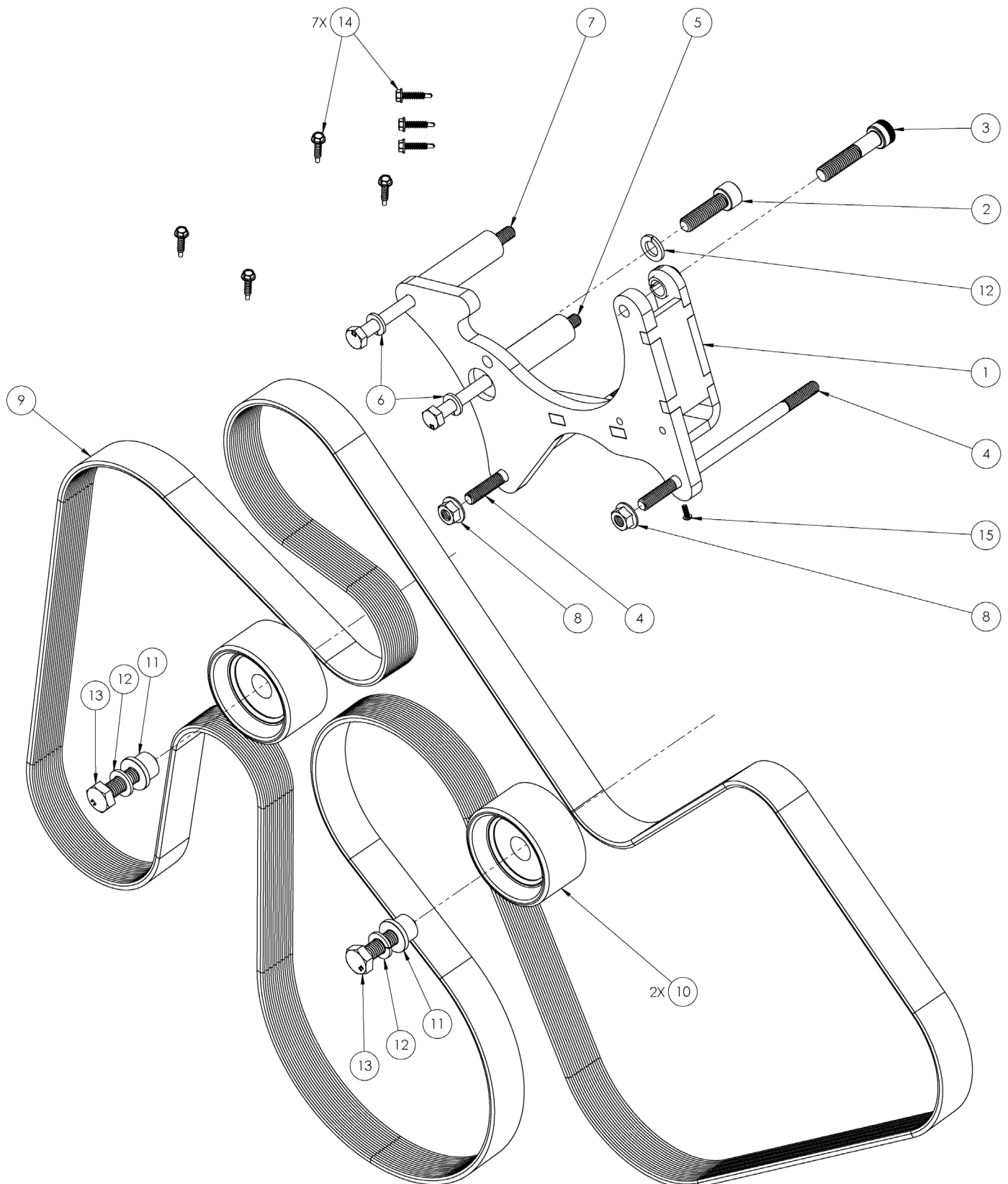

ITEM NO - Diagram 2	PART NUMBER	DESCRIPTION	QTY.
1	140-0156	"FORD SUPERDUTY, 2017+ POWERSTROKE 6.7, MAIN BRACKET WELDMENT"	1
2	920-0119	ZINC PLATED M10-1.5 x 35 SHCS	1
3	920-0269	ZINC PLATED M10-1.5 x 50 SHCS	1
4	920-0256	M8-1.25 X 160 DOUBLE-ENDED THREADED STUD	2
5	920-0254	M8-1.25 X 130 HEX HEAD BOLT - 8.8 - ZINC PLATED	1
6	925-0012	M8 LOCK WASHER	2
7	920-0097	M8-1.25 x 140HEX HD BOLT	1
8	920-0257	"M8-1.25 SERRATED FLANGE HEAD NUT - CLASS 8 - ZINC PLATED"	2
9	980-0082	SERPENTINE BELT, 8 RIB, 137.7"	1
10	981-0011	70mm IDLER PULLEY	2
11	14-0561	IDLER PULLEY CENTERING BUSHING	2
12	925-0016	M10 LOCK WASHER - ZINC PLATED	3
13	920-0019	M10-1.5 X 45 HEX HD BOLT - 8.8 - ZINC PLATED	2
14	920-0014	#8 X 3/4" HEX HEAD SELF-DRILLING SCREW	7
15	920-0004	M3-0.5 x 8 BUTTON HD SCREW - STAINLESS STEEL	1

1.3 Identification Sizing Table



M8-1.25 X 160mm THREADED STUD
920-0256 (2)



M8-1.25 X 140mm HEX HEAD BOLT - 8.8
920-0097 (1)



M8-1.25 X 130mm HEX HEAD BOLT - 8.8
920-0254 (1)

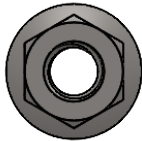

M8-1.25 SERRATED
FLANGE HEAD NUT
920-0257 (2)

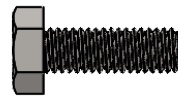

M6-1.0 X 18mm
HEX HEAD BOLT
920-0241 (2)

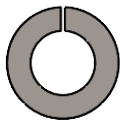

M8 LOCK WASHER
925-0012 (2)

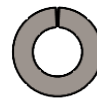

M6 LOCK WASHER
925-0020 (2)

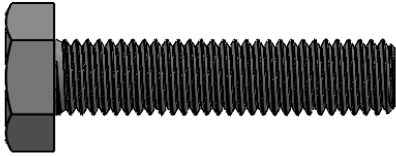

M10-1.5 X 45mm HEX HEAD BOLT - 8.8
920-0019 (2)

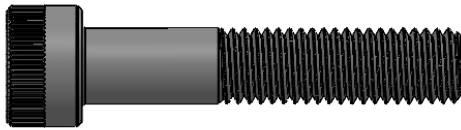

M10-1.5 X 50mm SHCS BOLT - 12.9
920-0269 (1)

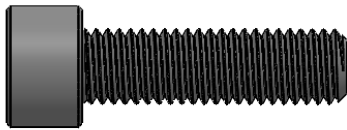

M10-1.5 X 35mm HEX HEAD BOLT - 12.9
920-0119 (1)

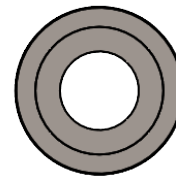

IDLER PULLEY CENTERING BUSHING
14-0561 (2)

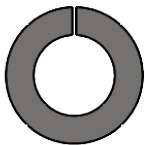

M10 LOCK WASHER
925-0016 (3)



M3-0.8 X 8mm
BUTTON HEAD SCREW - SS
920-0004 (1)



#8 X 3/4"
SELF-DRILLING SCREW
920-0014 (7)

2. Tools We Used



Breaker Bar

Pickup Tool

Gap/Feeler Gauge

2 13mm Open/Box End Wrenches

Torque Wrench

Crimper

Flashlight

Wire Cutters

Needle Nose Pliers

Channellock

Adjustable Wrench

Wire Stripper

Electrical Tape

Power Drill / Screw Gun

¼" hex drive Socket Adapter

¼" Manual Driver

3/8" Drive Ratchet

3/8 to ¼ adapter

10, 11, 12, 13, 15 and 17mm Short Well Metric Sockets

8mm Hex Bit Socket

10 and 11mm, Deep Well Metric Sockets

¼" and 1/8" Slotted Screwdrivers

#2 Phillips Screwdriver

3. Before you begin

Before you begin the installation, check the Kit Parts List against the content of the Installation Kit. If anything is missing or incorrect, contact Ventech immediately.

3.1 Best Practices

It is very important that the LHG be installed correctly not only to obtain maximum results, but also to minimize the possibility of unit failure. The following tips address some of the more common installation mistakes.

3.1.1 Fastener Torque

Torque all fasteners according to the instructions in this manual.

Excessive fastener torque may cause damage to the bolts and/or threaded components.

Too little torque may cause fasteners to loosen.

3.1.2 Use Threadlock – (Loctite)

Loctite 243 must be applied when and where noted in this manual.

4. About the Ventech HeatStroke LHG

The heart of the Ventech HeatStroke Rapid Supplemental Heater System is the proprietary Liquid Heat Generator (LHG).

By providing fast engine and cabin wamup, your engine will spend far less time “running cold,” saving fuel, and reducing wear & tear on the engine, various engine components, and after-treatment system.

The LHG generates coolant heat by the rotation of an internal ‘rotor’ opposing a stationary ‘stator’ within the LHG Heater assembly. Fluid friction is caused by a process known as toroidal vortexing or the shearing of toroidal vortices. The process is highly efficient (up to 98%) and instantaneous.

The digital ECU provided with the Ventech system determines when to activate the LHG, based on Coolant Temperature, Vehicle Voltage, Engine and LHG RPM, Ambient Air temperature, and other parameters monitored by the ECU.

The system is a fully automatic belt-driven vehicle accessory. A dashboard switch is provided for manual enable and disable of the system from within the cab.

5. Preparing for Installation

1. Remove the air intake hose.



2. Remove the air filter cover and filter.



3. Disconnect both batteries.



4. Remove passenger side battery.

NOTE: It may be necessary to also remove the battery housing/mount in order to reach the truck's accessory wiring during the installation process.



5. Release the serpentine belt.

Locate the belt tensioner on the front of the engine and using a socket wrench and breaker bar for leverage, release the fan belt tension and slip the belt off the pulleys.

You will not be able to fully remove the belt until after the next step.



6. Disconnect the bracket and the wires to radiator fan.

Locate the wires that power the radiator fan. Release the clip (see locking hook in illustration), pull the clip up away from the socket, and disconnect the wires. Be sure to save the clip for re-connection of the fan wires after LHG installation.

NOTE: While it is easier to do the installation with the entire fan disconnected, this requires special tools that you may not have. We suggest leaving the fan itself connected unless removing it is something you do regularly and have the proper tools to do quickly and easily.

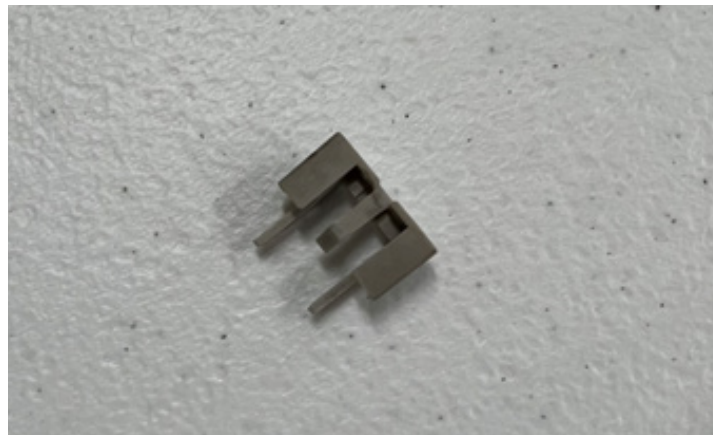
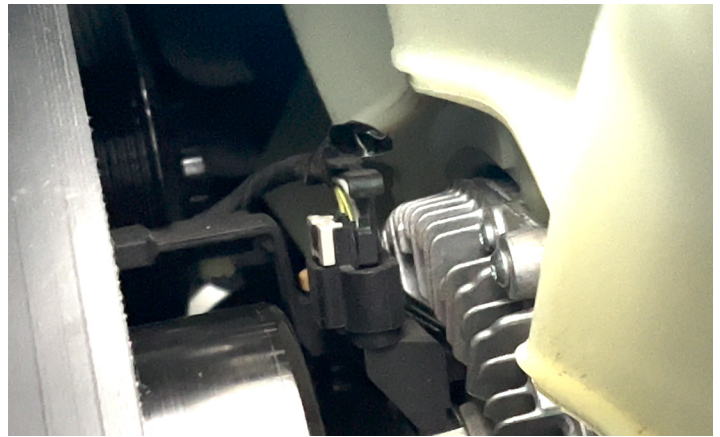

7. Remove the serpentine belt.

You can discard the serpentine belt. A new longer belt is supplied with the LHG kit.

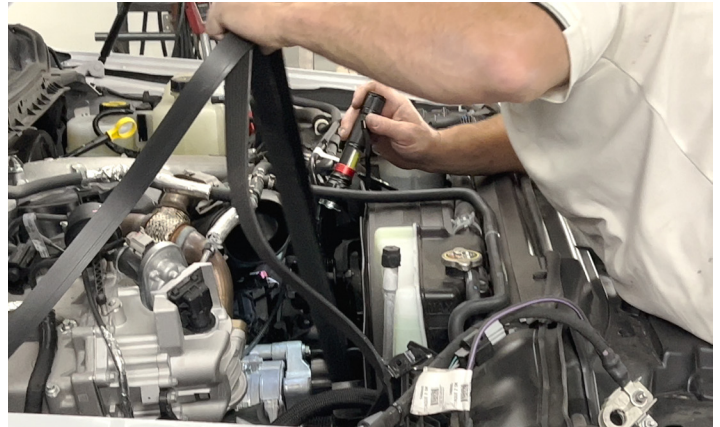

8. Remove driver side OEM idler pulley.

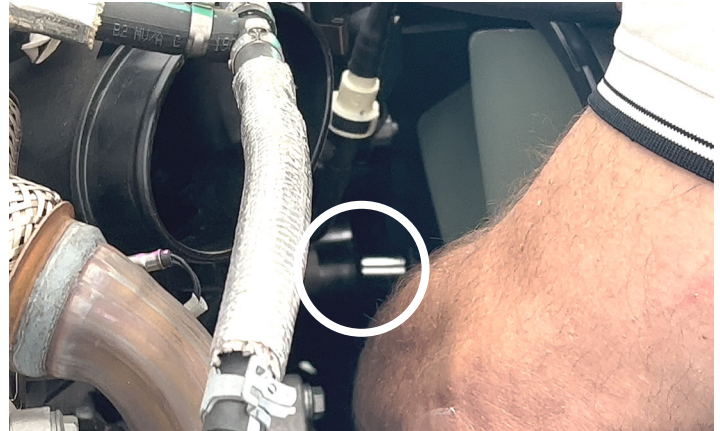
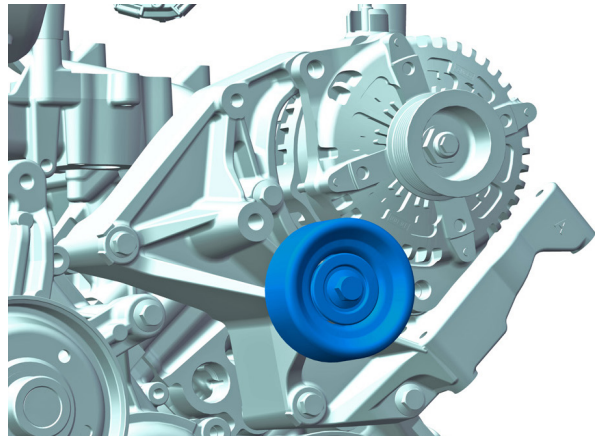

9. Remove the center OEM idler pulley.

Remove the passenger-side serpentine belt pulley. A breaker bar (as shown below) may be necessary to loosen the bolt.

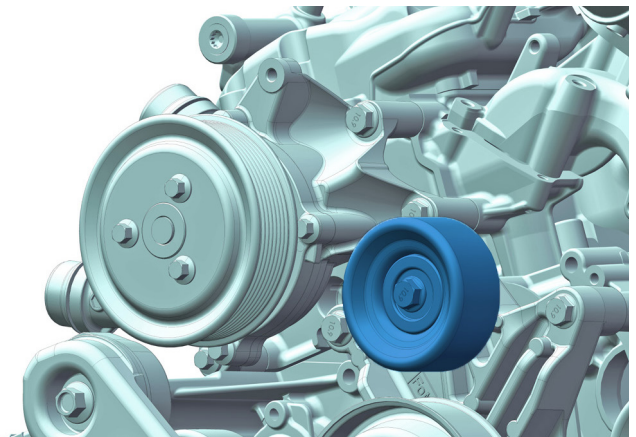

10. Remove the bolts indicated with white circles.

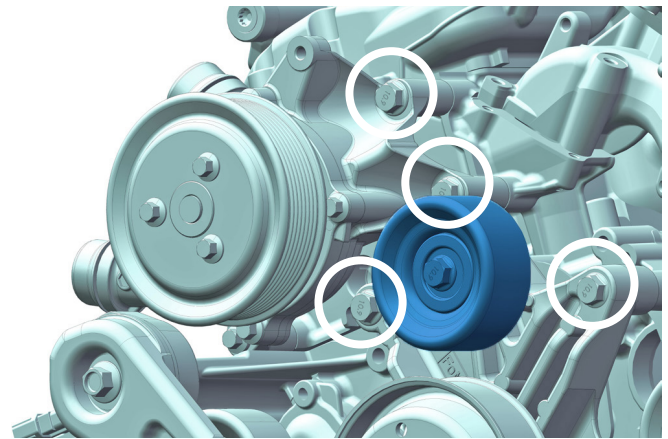

5.1 Complete the LHG Bracket Assembly.

Locate the installation kit items listed in the table to the below.

Part #	Desc	Qty
LHG700 DSS 34	HEATSTROKE LHG	1
140-0156	HEATSTROKE WELDMENT	1
140-0155	LHG ROTOR RPM BRACKET ASS'Y	1
920-0119	ZINC PLATED M10-1.5 x 35 SHCS	1
920-0269	ZINC PLATED M10-1.5 x 50 SHCS	1
920-0241	M6-1.0 x 18 HEX HEAD BOLT	2
925-0020	M6 LOCK WASHER	2
920-0004	M3-0.5 x 8 BUTTON HEAD SCREW	1
990-0004	4-WAY CABLE TIE MOUNT	1

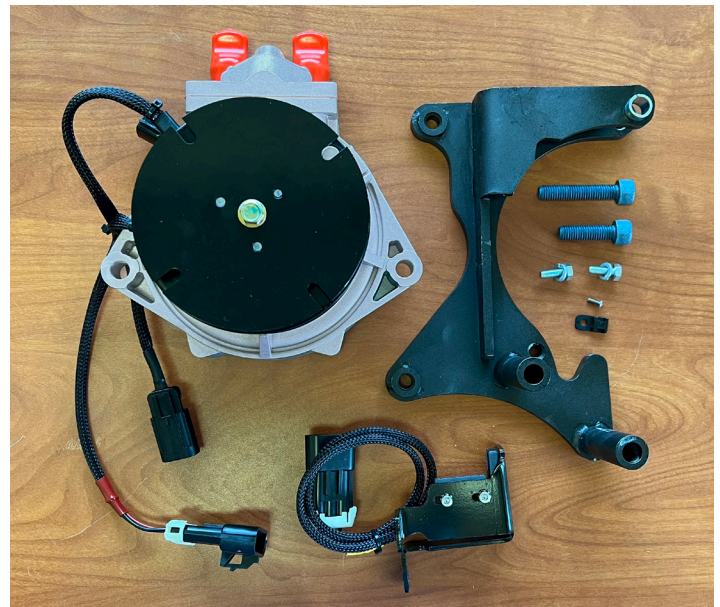

11. Install Cable Tie Mount.

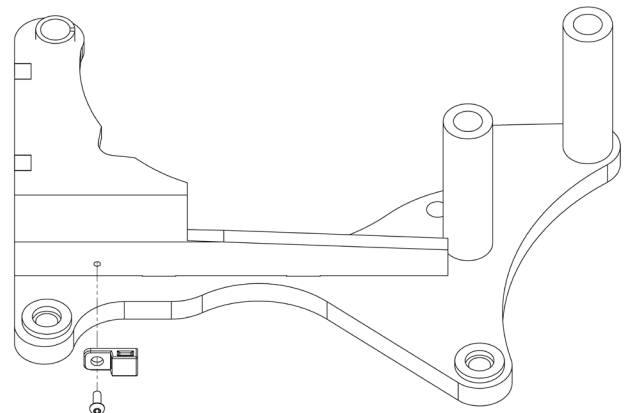

IMPORTANT

About the Following Section, LHG Bracket and Idler Pulleys.

While your Ventech Kit-supplied bracket and pulleys may look slightly different from the ones shown here, the differences should be minor.

Note that while these minor differences may exist and are to be expected, ALL supplied brackets, pulleys, and spacers MUST fit cleanly and firmly to the engine, and the new serpentine belt supplied with the kit should track in the center of the smooth idler pulleys.

If they do not, don't try to make them fit. Discontinue the installation and contact Ventech immediately.

12. Attach the LHG to the weldment.

Line up the holes on the bracket shown to the right with the mounting holes on the LHG.

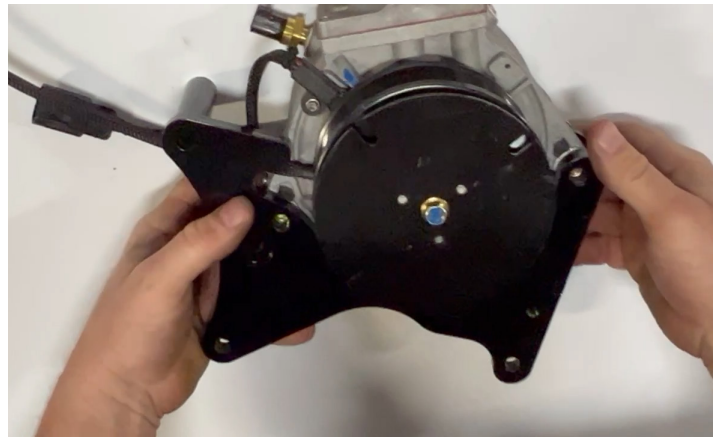

Be careful not to pinch clutch wire, making sure that the wire can move freely within the relief cutout shown here

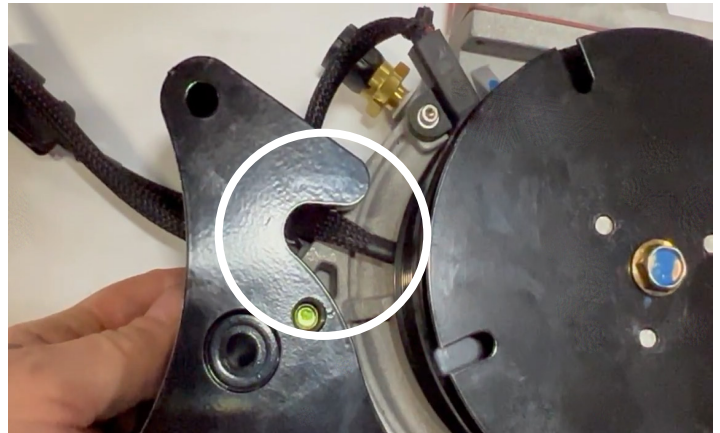

Insert the bolts from the rear of the LHG Assembly.

Check the weldment and make sure the bushing did not com out during shipping.



The ZINC PLATED M10-1.5 x 50 SHCS goes through the bushing. This is the left bolt in the illustration. It may make things easier to thread this bolt first.



Torque both bolts to 25 Nms or 18 ft-lbs.

13. Attach LHG Rotor RPM Bracket Assembly



Position the RPM Sensor Bracket Assembly as shown here and bolt it in place.



Torque both bolts to 10 Nms or 7 ft-lbs.

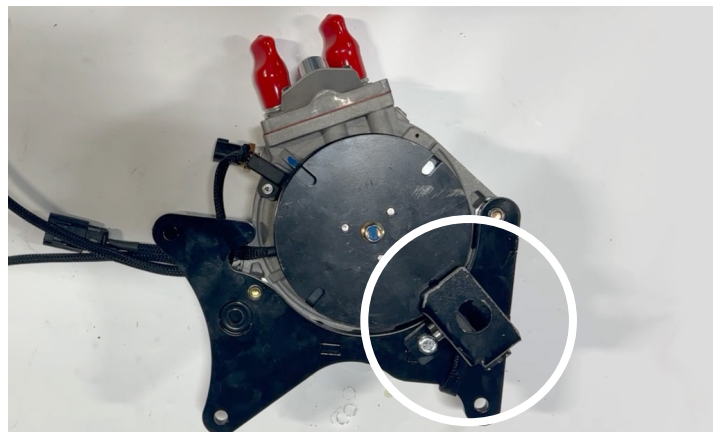

14. Check RPM Sensor Gap

Using a .020" or 0.5mm feeler gauge, check the air gap between the RPM sensor and the LHG speed disc.

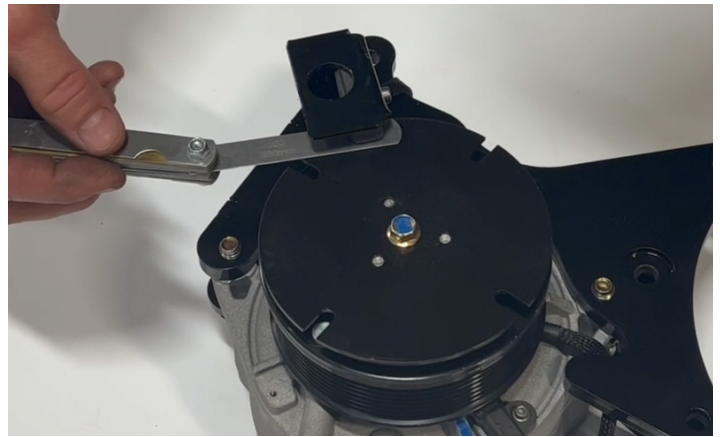

If the gap is too large or too small, loosen the bolts shown here, set the gap properly to .020" or 0.5mm, and re-tighten.



15. Secure the Wiring.

Using a Nylon Tie (part #990-0002) secure the sensor wiring to the Tie Mount you installed on the bracket just a few steps ago.

Be careful leave a small amount of slack on the cable. Do not pull it taut.

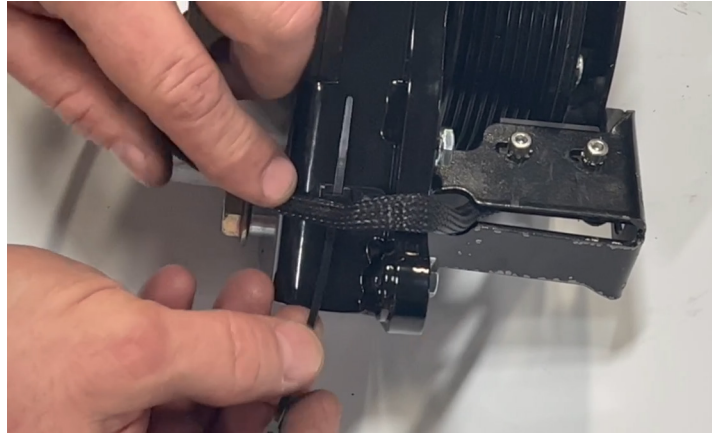

Preparation of the LHG Assembly is complete.



6. Mechanical Installation

6.1 Prepare and install the pulleys.

Locate the following parts from the installation kit:

Part #	Description	Qty
920-0011	M10-1.5 X 50 HEX HD BOLT	2
925-0016	M10 LOCK WASHER	2
14-0561	IDLER PULLEY CENTERING BUSHING	2
981-0011	70mm IDLER PULLEY	2

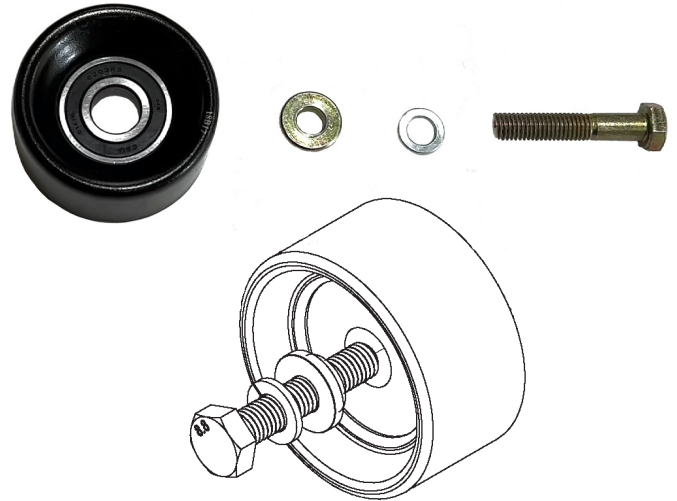

16. Assemble both pulleys in the following order: bolt, lock washer, centering bushing, idler pulley.

Make sure that the smaller radius side of the centering bushing is towards and fits inside the center of the bearing – the bushing’s flat side facing out.

17. Install one pulley assembly on the driver side of the engine, in the location shown here.

The illustration to the right shows the new driver side pulley in its proper location.

The **X** marks where the previous pulley was installed.

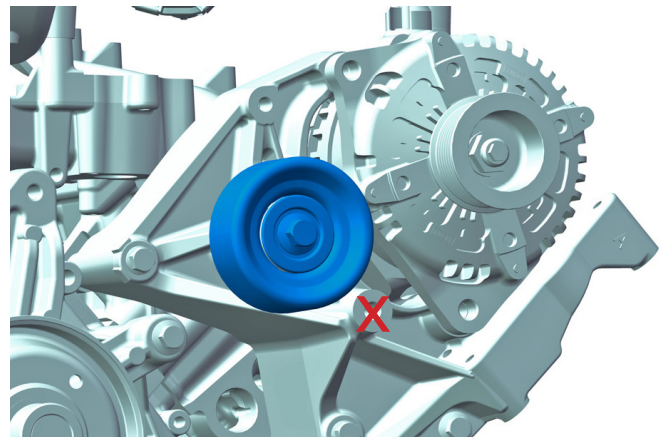

- Torque the bolt to 43 Nms or 32 ft-lbs.

18. Install the second pulley assembly in the center of the engine, at the location shown here.

The illustration to the right shows the new center pulley in its proper location.

- This bolt will be torqued to 43 Nms or 32 ft-lbs.

IMPORTANT: it may be easier to install the LHG Assembly if this pulley is left only loosely threaded at this point.

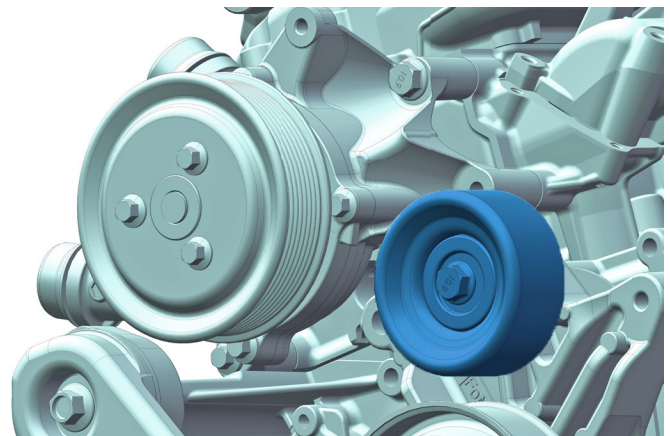

6.2 Prepare for LHG assembly installation.

Note: for the next steps (6.2.1 & 6.2.2) it may be necessary to loosen the two nuts on the fan pulley bracket shown to the right.

If the studs in steps 6.2.1 & 6.2.2 do not insert and turn freely, loosen (DON'T REMOVE) the bolts in the locations shown to the right. Verify that the casting is slightly loose and install the studs as described below.

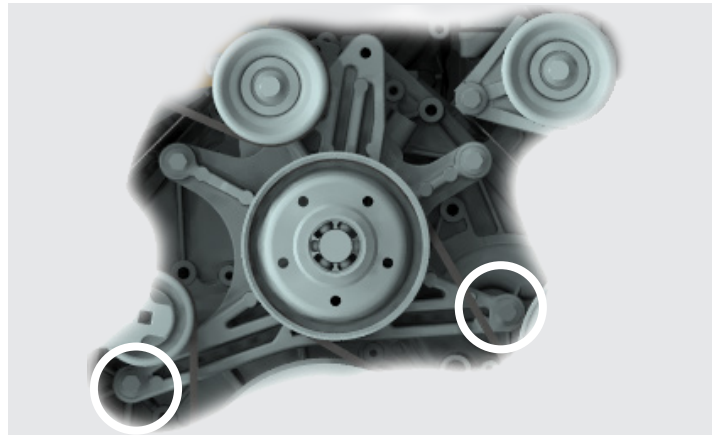

6.2.1 Install the first Stud

19. Insert one of the two studs (part #920-0256). The correct position for this stud is shown to the right with the center pulley installed (as it is at this point in the installation) and without the pulley installed (below right) for reference.

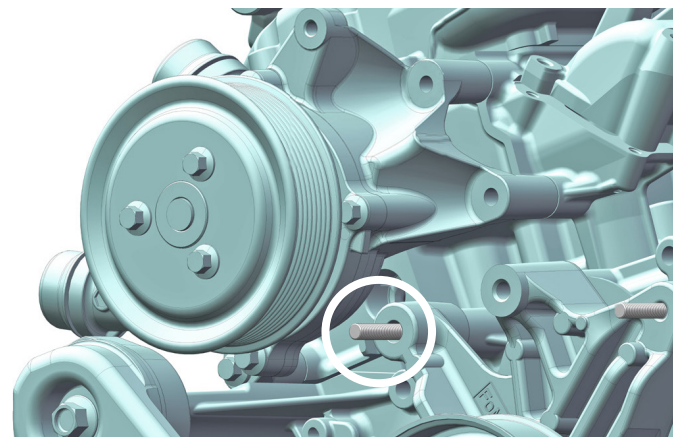
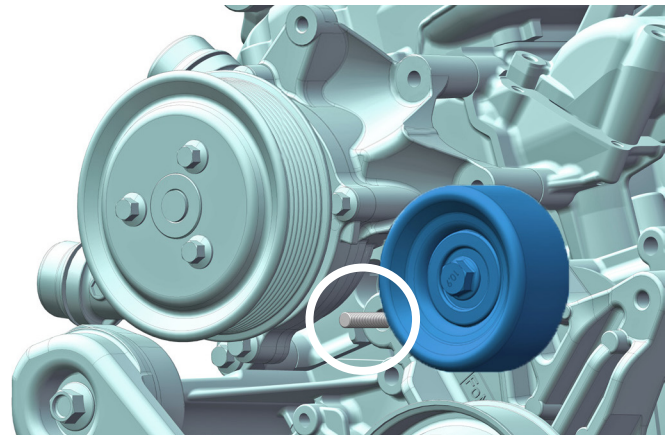

Use two nuts on the end of the stud (as shown below) to tighten it to the proper depth.

Install the stud to a depth of 1 inch (25.4mm).

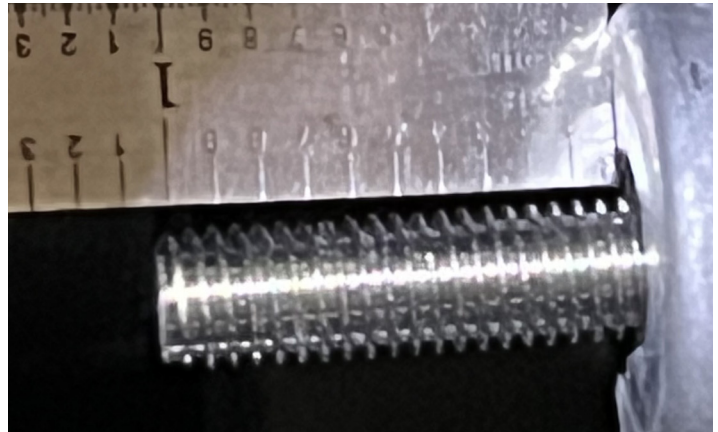
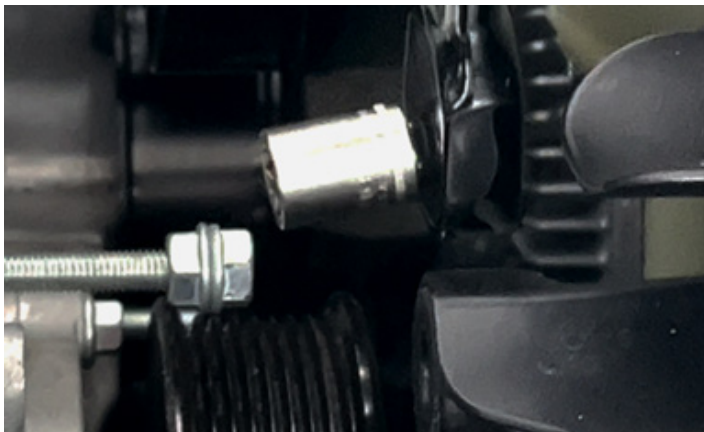

Remove the nuts and save for later.

6.2.2 Install the SECOND of TWO Studs

The correct position for this stud (also part #920-0256) is shown to the right with the center pulley installed (as it should appear) and without the pulley installed for reference.



20. As with the first stud, use two nuts on the end of the stud to tighten it to the proper depth.

Install the stud to a depth of 1 inch (25.4mm).

Remove the nuts and save for later.

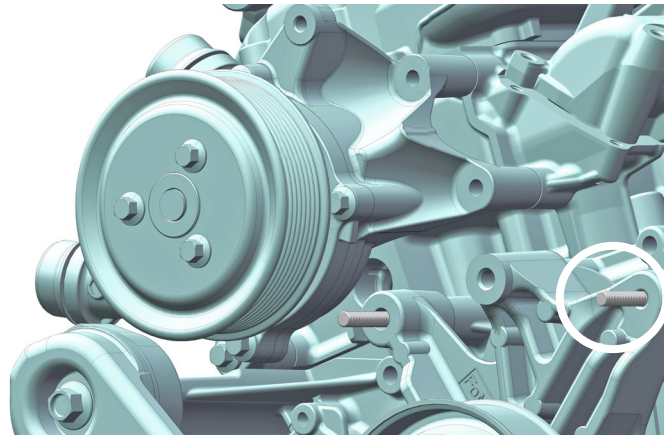
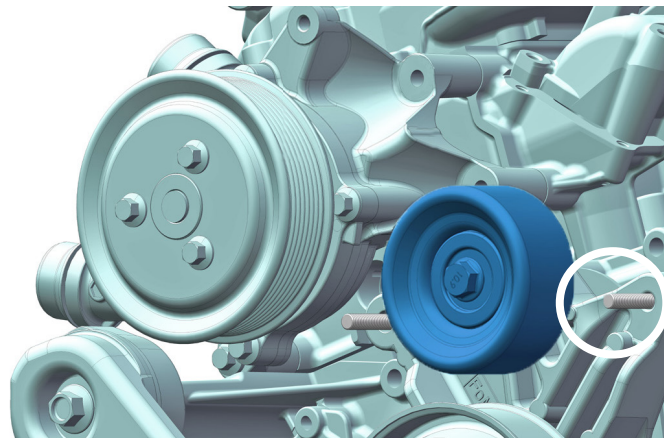

VERY IMPORTANT:

IF YOU LOOSENED THE 2 BOLTS ON THE FAN HUB in step 6.2 above, **MAKE SURE** you re-tighten both bolts and torque them to 22 Nms or 16 ft-lbs.

This MUST be done at this point, as completing this step will be difficult if not impossible once the LHG is installed!

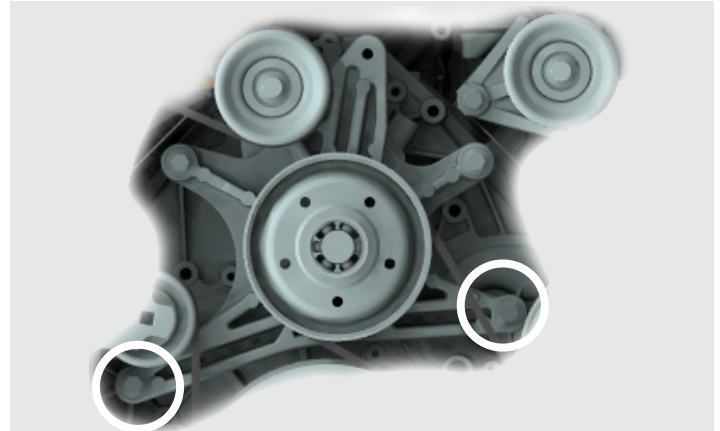

6.3 Move some wiring

In order to make room for the LHG, we suggest moving the OEM wiring connector attached to the bottom of the intake.



21. Detach the connector from its original mount (circled) and place it in the tray under the intake as shown.

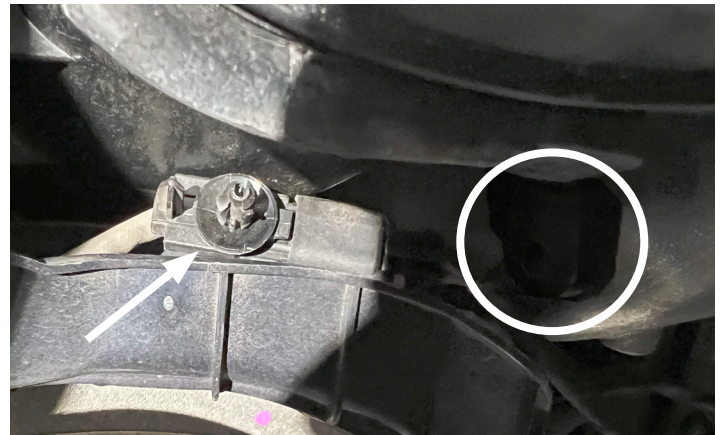

6.4 Install the LHG assembly.

IMPORTANT: the LHG assembly is heavy and contains parts that are sensitive to impact. Take special care when lifting and installing the assembly.

The area receiving the LHG assembly should appear as shown to the right, with the two studs awaiting the assembly.

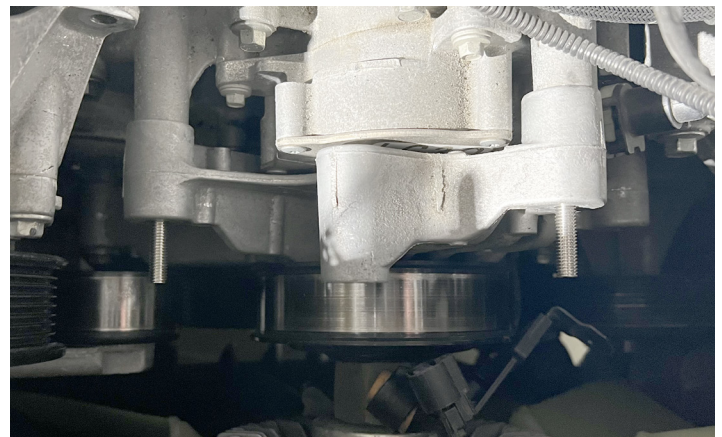

22. Carefully lift the LHG assembly, align the bottom two holes on the LHG bracket with the two studs and slide the assembly onto the studs.

23. Install and finger tighten the two M8-1.25 Flange Nuts (part #920-0257) onto the studs.

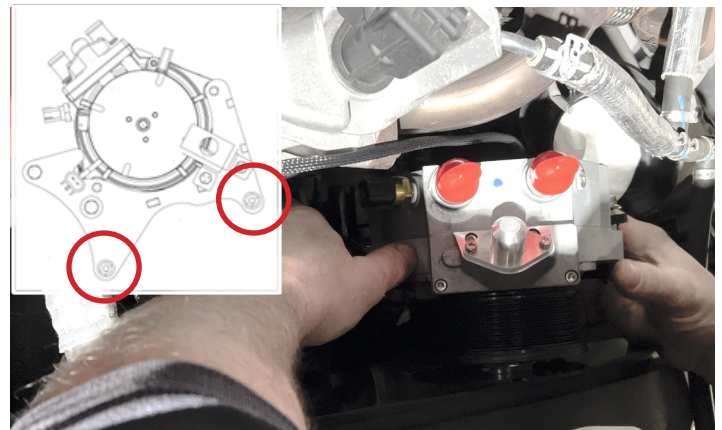

IMPORTANT

About the Upcoming Section, LHG Plumbing and Hose Routing

Hose routing is not set in stone.

Due to added accessories or model year differences in the location of the firewall pass-through from those shown here, you may wish to route the hoses differently. This will not affect performance.

IT IS IMPORTANT, regardless of routing, that hoses never be placed near hot or sharp objects and are never pinched or bent at an angle that will restrict fluid flow.

- 24. Install and finger tighten the M8-1.25 140 bolt (part #920-0097).

- 25. Install and finger tighten the M8-1.25 130 bolt (part #920-0254).

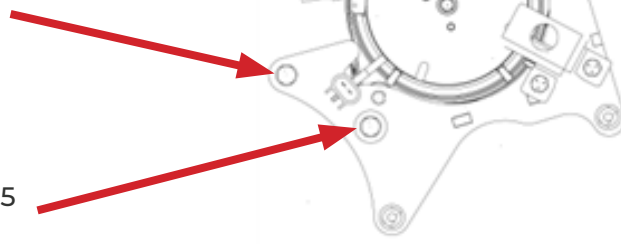

- 26. Torque the LHG Bracket mounting bolts and nuts to 16 ft-lbs.

IMPORTANT: if you did not tighten the pulley from section 6.1.18 DO IT NOW!

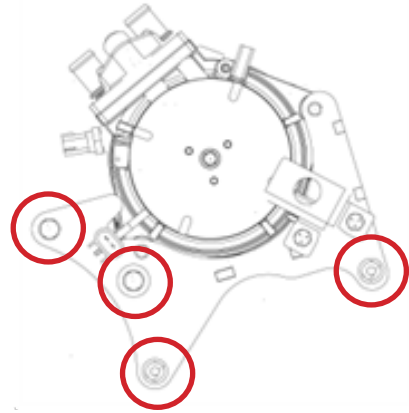

6.5 Install the new belt

- 27. Using the diagram to the right, install the new serpentine belt (part # 980-0082). We have found it easiest to:

- Have a second person help with running the belt.
- Begin by placing the belt around the tensioner. Then place the belt around the crankshaft, the fan, etc.
- Wait to put the belt under the driver side pulley (highlighted in the illustration). Save this pulley for last.
- Once the belt is in place and you have double-checked, pull back on the tensioner, release as much tension as you can, and slip the belt under the driver side pulley.
- Return tension to the belt, check to make sure it has not slipped off anywhere.

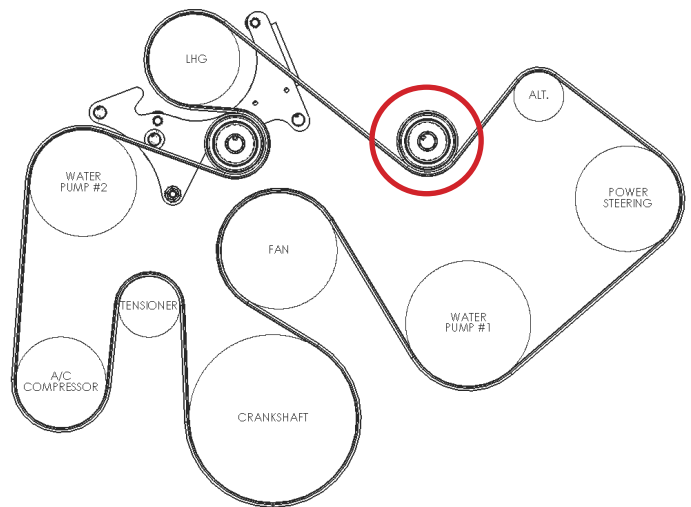

6.6 Install the new hoses

6.6.1 Trim the supplied hoses

28. At the angled end of both hoses, measure and mark about 2 7/8 inches down from the corner, or 1 1/4 inches up from the end.



29. Cut BOTH hoses at your marks.



6.6.2 Disconnect & Reroute the OEM Hose

IMPORTANT! Make sure the engine is cold and there is no pressure in the coolant system.

30. Begin by removing the lower coolant hose from the firewall pass-through.

Locate the proper hose. Remove and save the white locking ring. Then disconnect the lower hose.

Important Note: some coolant will drain out of the hose and firewall connection when removed. Coolant is extremely poisonous. Take measures to catch and properly dispose of leaked coolant.

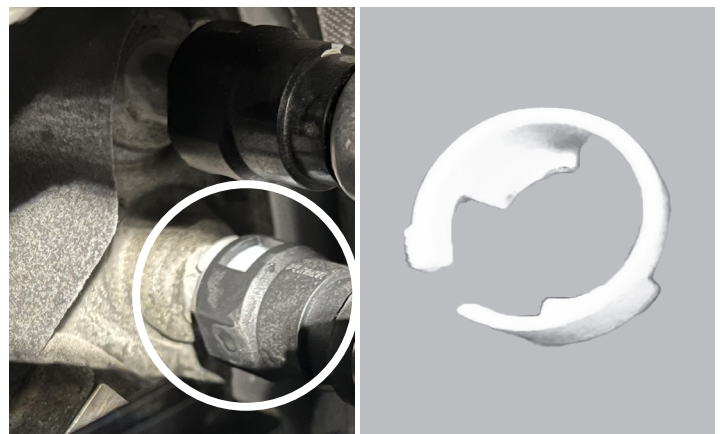
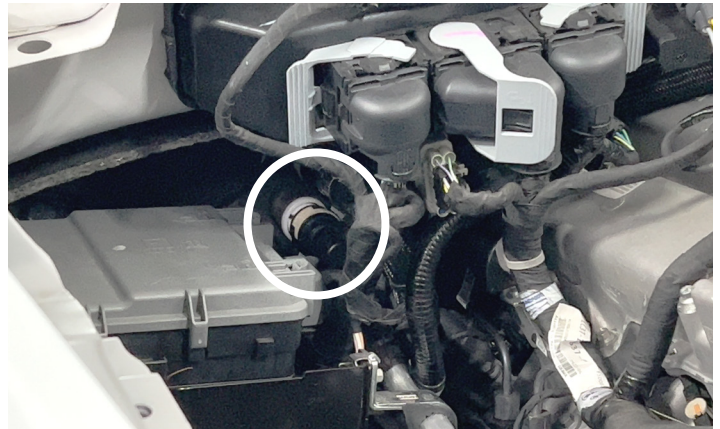

31. Reroute the OEM hose as shown here.



You may instead wish to route the hose below the wiring harness as shown below in its final and reconnected state.

Final routing can be determined when the LHG hoses are being connected.

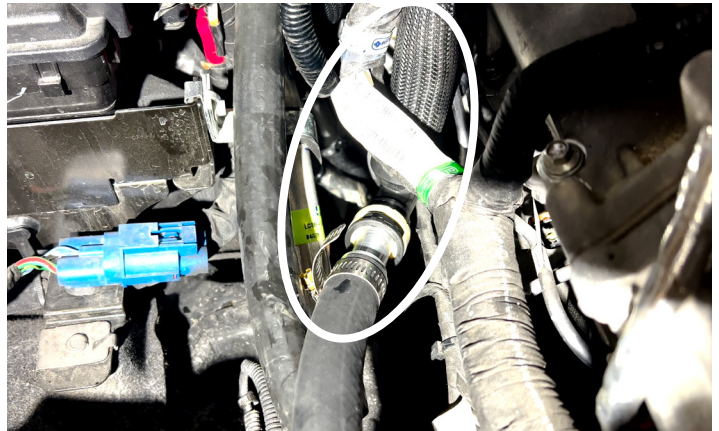

6.6.3 Prepare and connect the output hose from the LHG.

The LHG kit hoses (part # 990-0045) are longer than required and must be cut to the proper length.

32. Connect but do not secure one hose to the output (left/lower) coolant hose connector on the LHG.

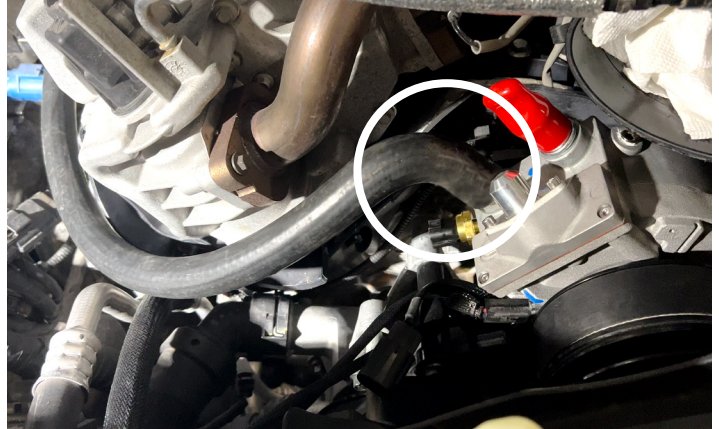

Run the hose around to the firewall connector.

DO NOT pull it tight – allow for space between hot engine parts and the hose. Also consider that you will be installing a quick-connect on the firewall end that will add about 1.5” to the final length. Best to error on the long side.

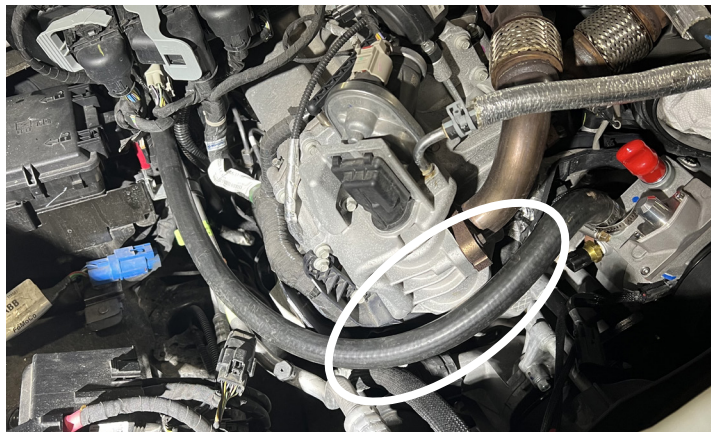

- 33. Cut the hose to proper length.
- 34. Install the quick connect (part #990-0216) using one of the supplied hose clamps (part #990-0093).



- 35. Connect and secure the hose to the LHG output connector using one of the supplied hose clamps (part #990-0093) angling it away from hot engine parts.



- 36. Route the hose to the firewall with the quick connect end as close to parallel to the firewall connector as possible (this will make it easier to connect).

- 37. Connect the quick connect to the firewall connector, making sure it clicks into place and verify that it is securely in position.



6.6.4 Prepare and connect the input hose to the LHG.

- 38. Connect but do not secure the remaining LHG Kit supplied hose (part # 990-0045) to the input (right/higher) LHG input connector.

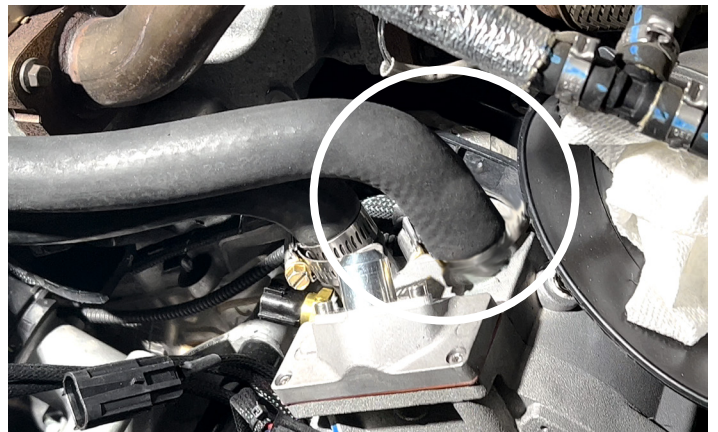

IMPORTANT

About the Upcoming Section, LHG Wiring and Power

As with plumbing, other than ensuring the proper connections are used between the LHG and the ECU, the wire routing, switch position, and power sources are not set in stone.

ECU location and mounting style can, and in some cases must be different than shown in this manual. The use of zip ties and/or Velcro tape may be more effective than the supplied ECU Mounting Bracket.

The location of the firewall wiring pass-through (and even its existence) will differ from model year to model year. Locate and use whatever resources work best for you.

Also, the fuse configuration will be different from year to year. The LHG switch requires a five (5) amp power source that is fused and controlled by the “ignition” switch (accessory on).

The Fuse Tap supplied in the kit should not be used in an OEM fuse location greater than ten (10) amps. Other than these requirements, the power source does not matter. Use what is functional and convenient for you.

39. Route the hose around the engine to the quick connect on the OEM hose that you disconnected and rerouted in step 31 above. Route the hose outside and slightly above the output hose, making sure it will not come into contact with hot engine parts.

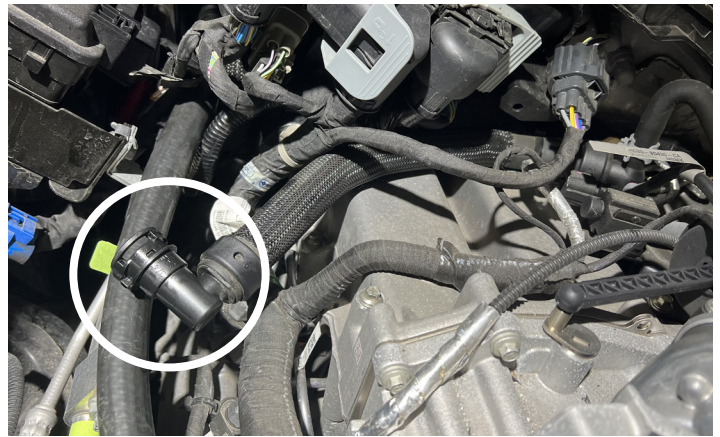

As you determine the length for the input hose consider that you will be installing an adapter on the non-LHG end that will add about 1" to the final length after it is connected to the quick connect.

It is best to err on the long side as the hose can always be shortened.

40. Cut the hose to the proper length.

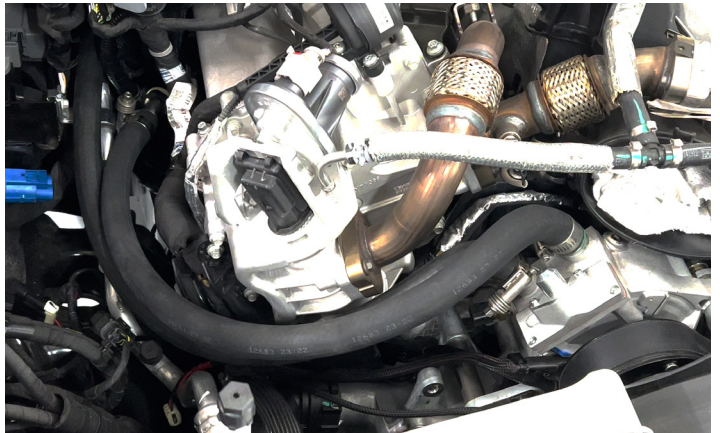

41. Install the hose adapter (part #10-0555) using one of the supplied hose clamps (part #990-0093).



42. Connect and secure the hose to the LHG output connector using one of the supplied hose clamps (part #990-0093) angling it away from hot engine parts.



43. Connect the adapter to the OEM quick connect and secure it with the locking ring saved from when the OEM hose was removed from the firewall.

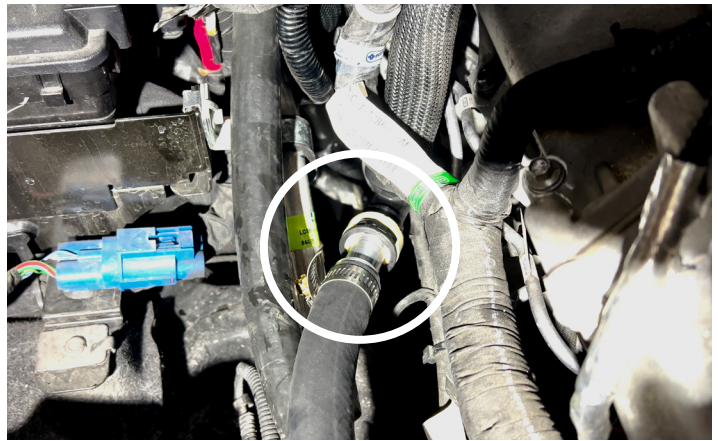

44. Complete the hose installation by using the 11" Nylon Tie Wraps (part #990-0001) to attach the hoses to each other, other secure components, and to keep them away from any hot engine parts.

Nylon ties can be abrasive. Consider using split loom (not supplied) on hoses that will be held with nylon ties.



6.7 Prepare and Install the LHG ECU

Locate the LHG ECU (part #135-0041) and the ECU Bracket (part #14-0556).

The ECU will be positioned in the upper corner of the firewall on the passenger side.



45. With the ECU and the bracket held together, position the top of the bracket no more than 1/2 inch below the overhang (NOTE: any lower and the ECU plug may interfere with the battery terminal).

46. Mark where to drill pilot holes for the bracket mounting screws.



47. Using a 1/8" drill bit, pre-drill the holes for mounting the ECU Bracket to the firewall.

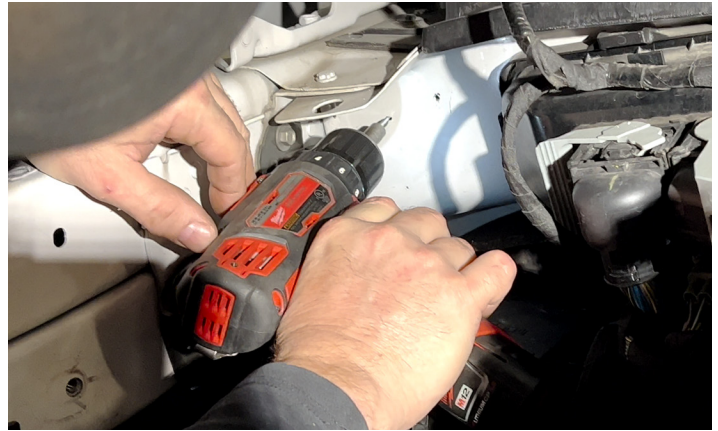

48. Using 4 of the self-drilling screws (part #920-0014), attach the ECU to the ECU Bracket.



49. Using the remaining screws (part #920-0014) mount the bracket to the firewall.



6.8 Install the wiring harness

6.8.1 Connect the LHG and ECU

49. Begin by plugging the wiring harness into the ECU.



50. Route the harness to the LHG and locate the harness clutch connector (black) and the temperature sensor connector (gray).

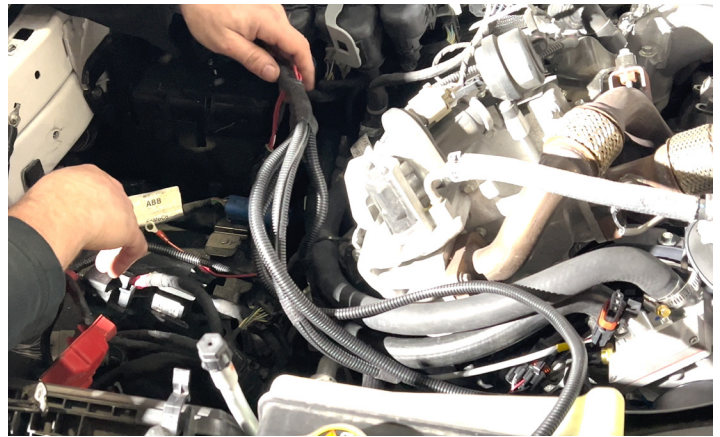

51. Attach the connectors for the temperature sensor (Gray on the harness, black with brass directly mounted to the LHG).

52. Attach the connectors for the LHG clutch (both black connectors).

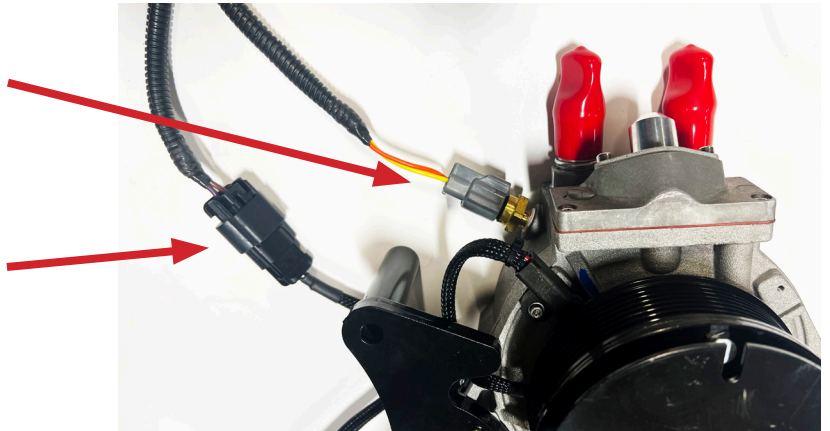

53. Locate the RPM sensor connections 2 female from the LHG and 2 male from the wiring harness.

These connectors are the same size and fit but are shrink-wrapped with different colors (yellow and red) where the wires enter the insulation.

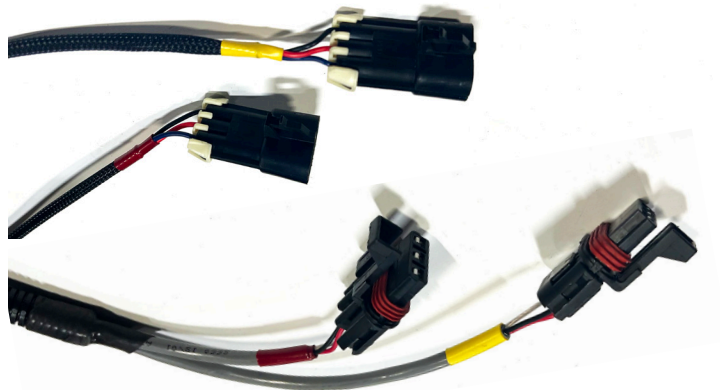

54. CONNECT YELLOW TO YELLOW AND RED TO RED.

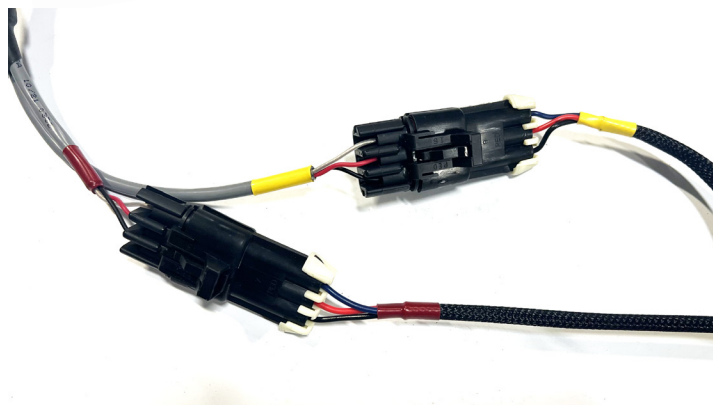

6.8.2 Position & Secure the OATS

On the wiring harness, locate the Outside Ambient Temperature Sensor (OATS).



55. Being careful to stay away from moving parts and hot objects, snake the sensor through the engine compartment to the underside of the truck.

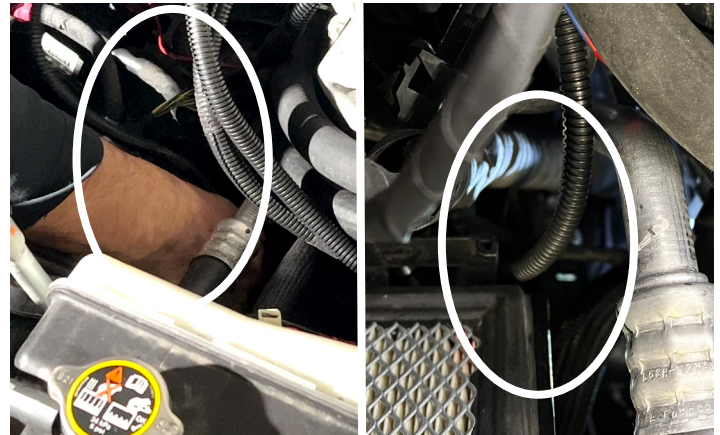

56. Using the supplied tie wraps (part #990-0001) secure the ambient temperature sensor to the undercarriage away from pinch points and any sources of heat.

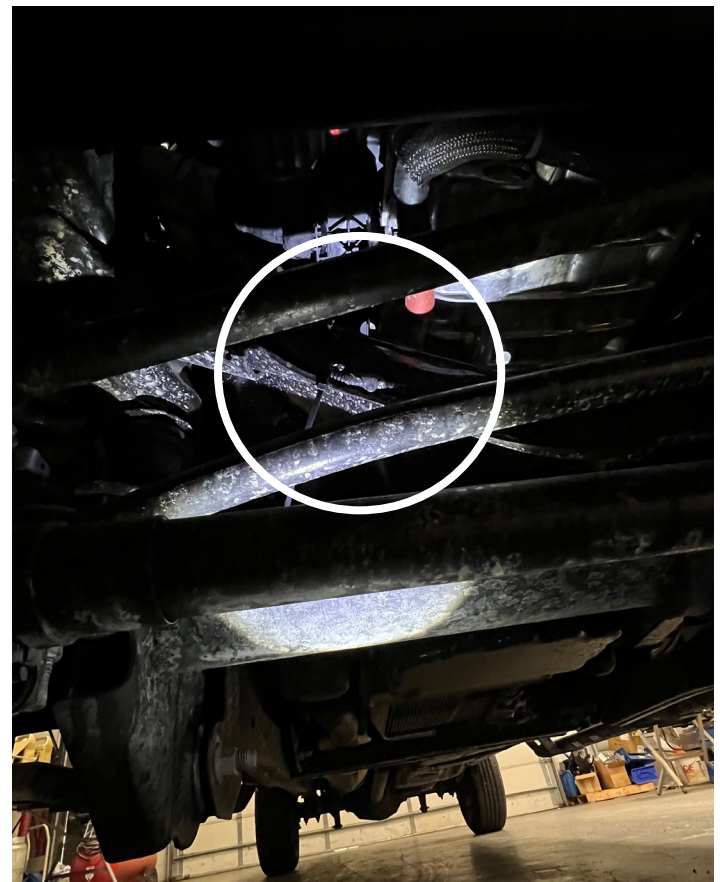

6.8.3 Connect the Wiring Harness to the OEM Firewall Pass Through Wires

57. Locate the OEM wires that pass through the firewall and remove the insulation from the ends.

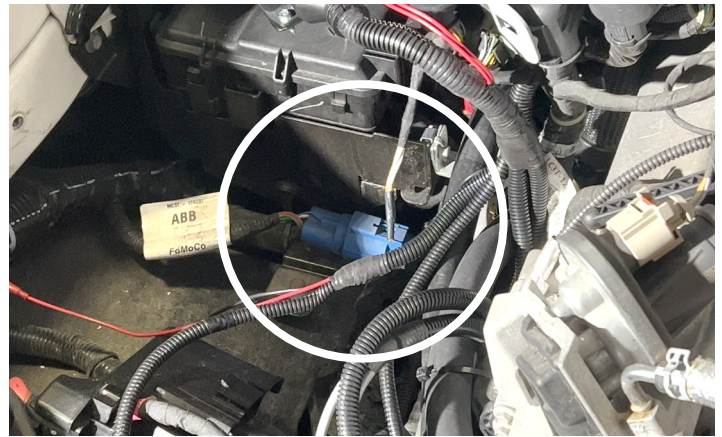

58. Identify and separate out the white and white with orange wires.

59. Strip about ¼ inch of the insulation off both the white and the white with orange wires.

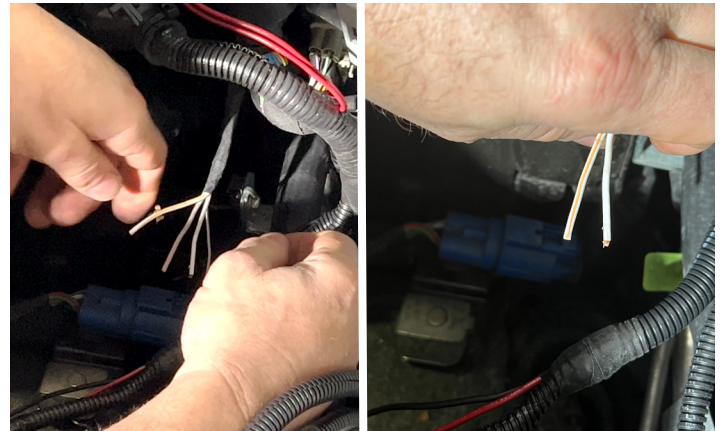

60. From the LHG wiring harness, locate the pink and gray wires with crimp connectors already attached.

61. With a crimping tool, attach the pink wire to the white with orange wire and the gray wire to the white wire.

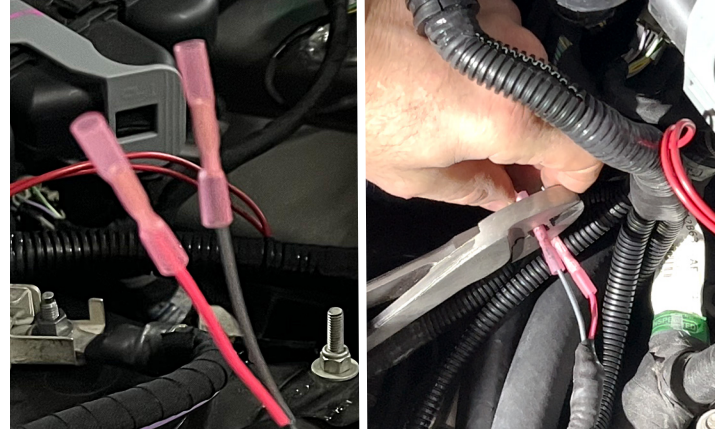

62. Finally, use a heat gun or other method to shrink the insulation and seal the connections.



6.9 Install the LHG switch in the cab.

63. Begin by preparing the lower driver's side dash cover to receive the LHG switch. Disconnect the top of the cover as shown here.

The switch will be positioned in the area just to the left of the steering column shown here.

You will be drilling a 3/8" or 16mm hole to receive the switch.



64. Protect the area before drilling by adding some masking tape to the surface as shown.



65. Next, locate the template in Appendix B of this manual.

Print the template making sure not to scale the drawing while printing it. There is a 1" (25.4mm) reference line on the template. Measure this after printing to make sure the print is to scale before using it.

The template is shaped to fit the contours of this section of the cover.

66. Carefully cut out the template along the outer contour line.

Do not cut out the target circle.

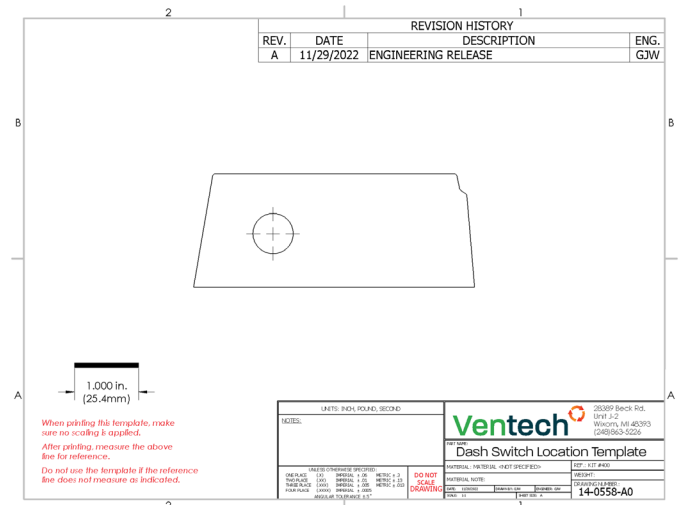

67. Fit the template to the shape of the dash cover as shown here and, carefully tape into place.



68. Using a cone drill, or a 5/8 or 16mm drill bit, carefully drill a hole for the switch at the target location. If using a standard drill, you should drill a pilot hole first.



69. Remove the template, masking tape, and any burrs or rough edges from the hole.

70. Locate the Switch Assembly (part #135-0042). And the Cab Switch Decal (part #13-0011)

71. Remove the locking nut from the Switch Assembly, unthread it from the wires, and save it for later.



72. Thread the Switch Decal onto the wire and up to the Switch.

73. Thread the wires through the hole you just drilled. Thread the locking nut back through the wires, being careful that teeth are in the proper direction towards the underside of the cover.

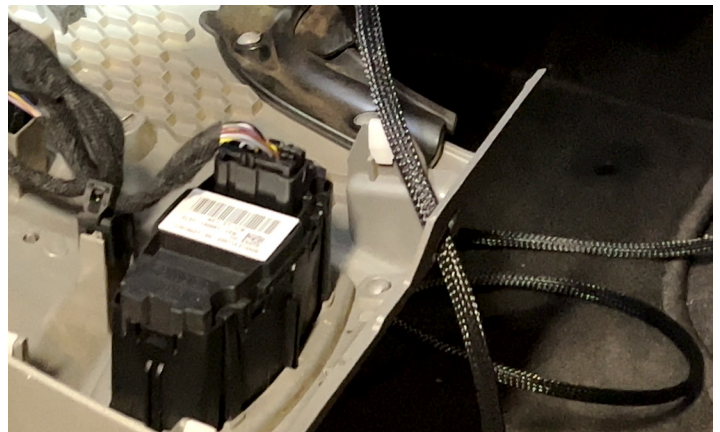

74. Expose the adhesive on the decal, position the switch and decal as shown, and secure them with the locking nut.



75. Pass the switch wiring into the dash. Then return the lower dash cover to its original position.

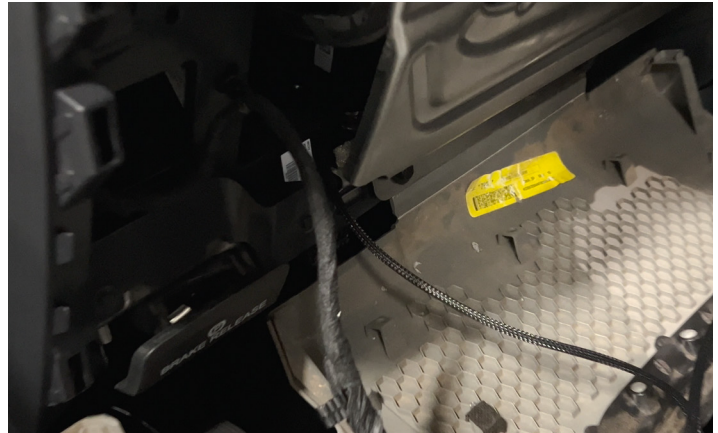

76. Move to the passenger side of the cab and remove the cover from under the glove box.



77. Remove the lower cover shown here.



78. Attach the ends of the switch wire to something stiff like a welding rod or straightened clothes hanger to assist in threading it under the center of the dash. There are a number of locations where it will easily pass through.

CRITICAL: Do not allow any of the wiring to be near or come in contact with sharp edges or moving parts or to droop down where it may interfere with the driver. Use the small nylon ties supplied (part # 990-0002) to secure it in place.

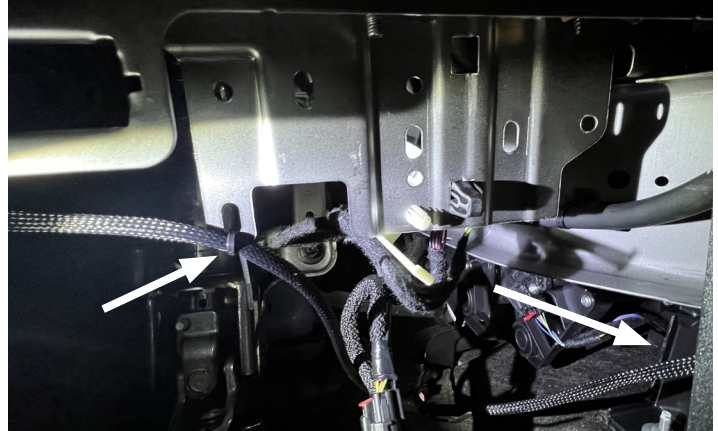
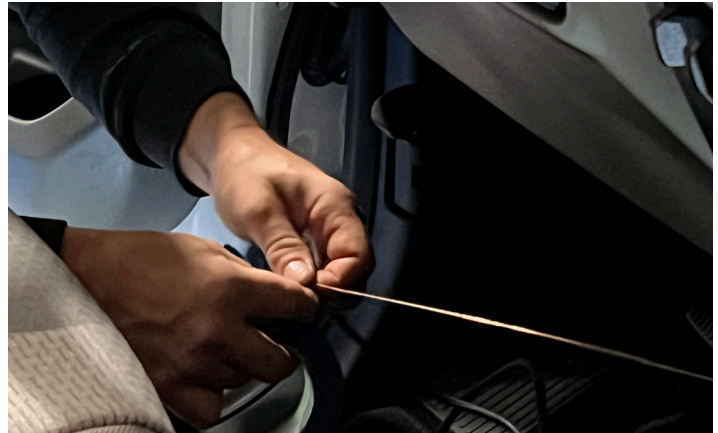

79. Within the fuse box inside the cab on the passenger side, locate the white wire and the white with orange wire that come through the firewall.

These will be the same two wires coming through the firewall under the hood and used in section 6.8.3 above.

80. Remove tape and insulation from the ends of these wires.

81. Strip about ¼ inch of the insulation off both the white and the white with orange wires.

82. From the switch wires, locate the pink and gray wires with crimp connectors already attached.

83. With a crimping tool, attach the pink wire to the white with orange wire and the gray wire to the white wire.

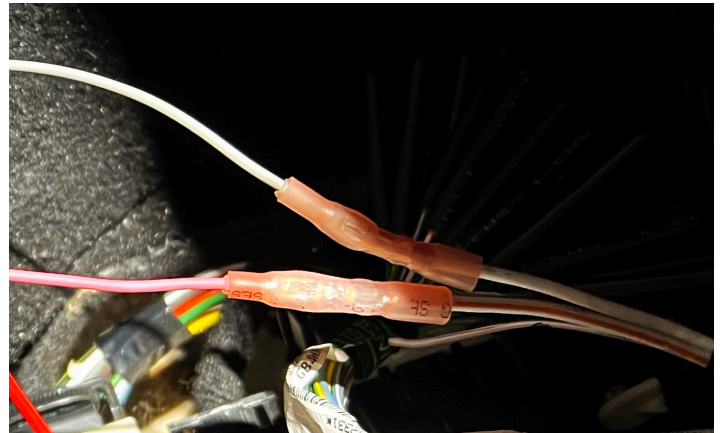

Locate the Fuse Tap (part #95-0060) and, using the same method, connect it to the blue wire from the switch wiring.

Insert the supplied 5-amp fuse (part# 96-0034) into the top slots on the Fuse Tap.

84. Use a heat gun or other method to shrink the insulation and seal the connections.

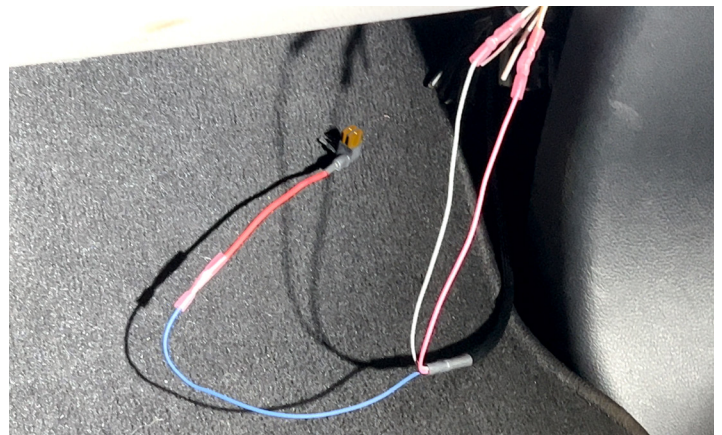

85. In the fuse panel located inside the cab in front of the passenger door, locate position 35. If there is a fuse in this position, remove it and add it to the lower slots on the Fuse Tap so there are 2 fuses in the Fuse Tap.

Then insert the Fuse Tap as shown.



86. Use the Nylon ties provided (part #990-0002) to secure all of the wiring out of the way.

87. Replace all the covers, and you are finished inside the cab.

7. Reconnect the batteries.

90. Reinstall/reconnect both batteries.

7.1 Connect the LHG to power

91. Connect the Black and Red leads from the LHG Wiring Harness to the battery as shown here.

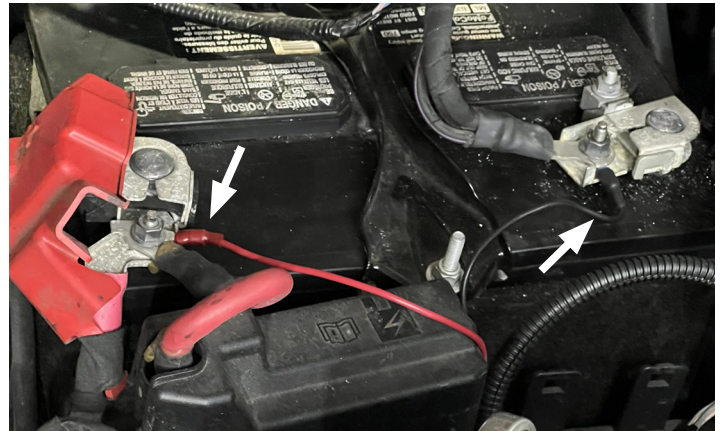

8. Secure the wiring harness

92. Using the nylon ties provided (part #990-0001 and 990-0002), route the wiring harness away from hot, moving, or sharp objects and secure it safely, creating service loops where there is extra length. At no point should wires be pulled tightly.

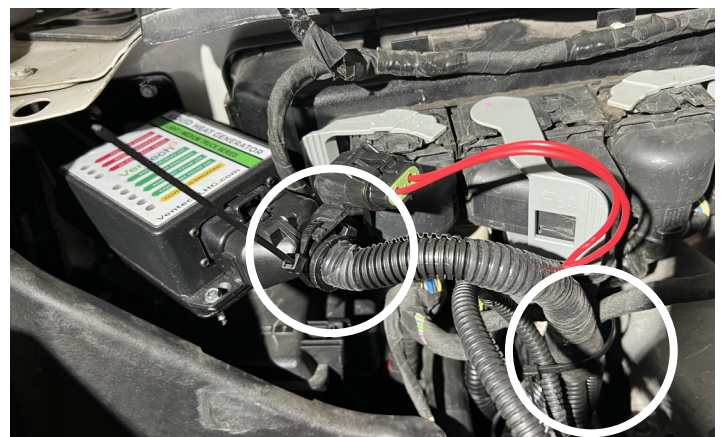

9. Complete the installation

93. Reconnect the radiator fan wires.

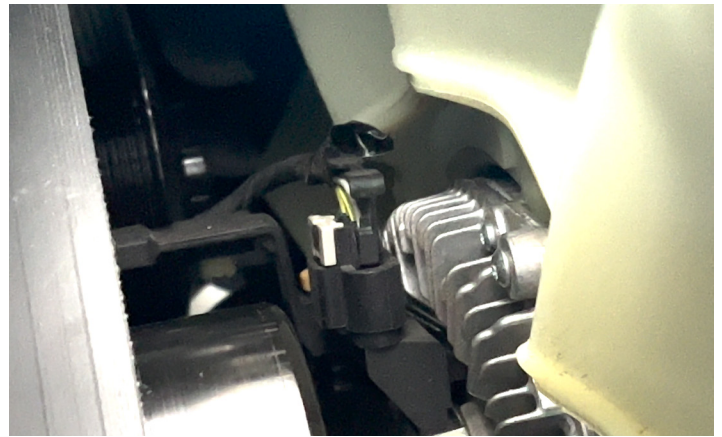

94. Top off the coolant if the reservoir is low. Check and top off again after the initial run with the LHG is complete.



95. Remove the rag from the intake and replace the air filter, filter cover and intake hose.



96. Make sure the OATS is properly secured under the truck (see section 6.8.2).



10. Final Inspection

- 97. Inspect installation for:
 - 98. Loose fasteners.
 - 99. Coolant leaks.
 - 100. Loose heater hose clamps.
 - 101. Pinched heater hoses.
 - 102. Loose wiring connections and battery connections.
 - 103. Ensure heater hoses are properly routed and protected against chafing and related damage.
 - 104. Ensure the wiring harness is routed properly and protected against chafing and related damage.
 - 105. Secure and dress harness using cable ties. Ensure that each harness termination point has some excess length to prevent unnecessary pulling on each connector.
 - 106. Make sure you have reinstalled all vehicle parts, panels, and components removed during LHG installation.
-

**THE FOLLOWING PAGES CONTAIN
IMPORTANT INFORMATION.**

**PLEASE READ
BEFORE STARTING
THE SYSTEM FOR THE FIRST TIME**

11. Initial Start-up

11.1 Initial startup behavior

11.1.1 AIR PURGE

Firstly, the LHG ECU will disable the LHG for the first three (3) minutes of operation (engine idling). During these first three minutes, any air that may remain in the LHG coolant circuit will be purged from the system (air-purge).

During the Air-Purge all green LEDs on the ECU will cycle in sequence.

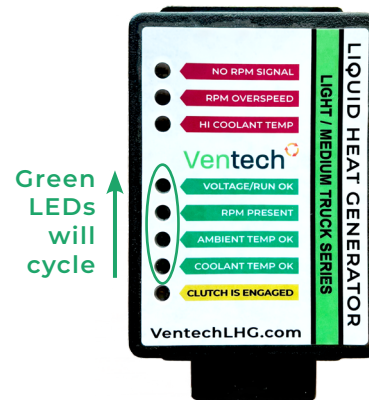

11.1.2 BURNISHING

The second run-up sequence step is an automatic Burnishing of the LHG's electromagnetic clutch. This step also takes about three (3) minutes and must be performed at Idle. During this second run-up sequence, the electromagnetic clutch will be cycled (burnished) 50 times. This burnishing process cleans the clutch surfaces that may have residue build-up from the LHG's time in storage.

During the Burnishing the yellow LED on the ECU will blink on and off.

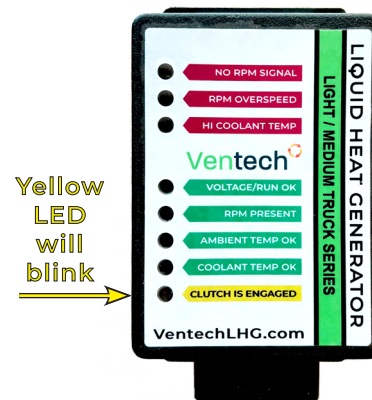

11.2 The first start

Start the vehicle engine and run at idle for ~6 minutes allowing the two run-up sequences to complete (air-purge and burnishing sequences).

11.3 Concluding the installation

While the engine is running, but after the two run-up sequences have been completed, check the following:

Hose connections for leaks.

Coolant level in the coolant recovery tank (add coolant as needed).

Appendix A: The LHG ECU (Digital Controller) Strategy

The Electronic Control Unit is designed to determine when to engage and disengage the LHG (via the LHG electromagnetic clutch) depending on various parameters, including temperatures, RPMs, vehicle voltage, internal timers, and other conditions.

Note: RPMs referenced below are LHG RPM, not Engine RPM. Kit #400 (Ford HeatStroke LHG) has a 1:1.66 ratio between Engine RPM and LHG RPM.

To the right is a summary of the parameters and set-points that determine whether the LHG will engaged or disengaged.

ALL the engagement parameters must be met to activate the clutch, while ANY individual disengagement parameter will deactivate the clutch.

NOTE: When the LHG clutch disengages, it will not re-engage until:

All conditions required to engage the clutch are met as seen above and 2 to 5 seconds has elapsed after ALL engagement parameters have been met (time delay varies depending on parameter).

Understanding the ECU LEDs during Normal Operation and as a Diagnostic Tool.

The Ventech ECU is equipped with 8 colored LEDs that indicate the operational status of the LHG heater system.

Three (3) LEDs are Red with corresponding descriptions (“No RPM Signal”, “RPM Overspeed”, and “Hi Coolant Temp”).

The Red LEDs are known as “Off-Flags”. Any illuminated Off-Flag will cause the LHG clutch to disengage.

LHG Clutch Engages WHEN ALL OCCUR SIMULTANEOUSLY	LHG Clutch Disengages IF ANY ONE OCCURS
LHG RPM greater than 255 RPM	LHG RPM less than 256 RPM
and	or
LHG RPM less than 2,600 RPM	LHG RPM greater than 6,000 RPM
and	or
LHG Temperature less than 167°F (75°C)	LHG Temperature greater than 185°F (85°C)
and	or
Supply Voltage is above 13.0V (5 second delay),	RPM signal is unstable (rate of change > 400)
and	or
Outside Ambient Temperature (OATS) is less than 50°F (10°C)	Voltage to ECU is below 12.0V
	or
	RPM-RPM Differential >150 RPM over 50 milliseconds
	or
	RPM-RPM Differential 50-150 RPM over 3 seconds

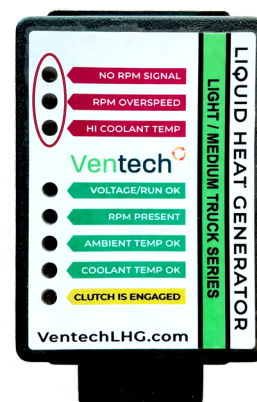

Four (4) LEDs are Green with corresponding descriptions (“Voltage/Run OK”, “RPM Present”, “Ambient Temp OK”, and “Coolant Temp OK”).

The Green LEDs are known as “On-Flags”. Every On-Flag must be illuminated for the LHG clutch to engage.

One (1) LED is Yellow: “Clutch Engaged” (LHG heater is engaged and producing heat).

The LEDs emulate the key parameters detailed in Figure 10. In order for the LHG to engage, ALL Green LEDs must be ON and ALL Red LEDs must be OFF.

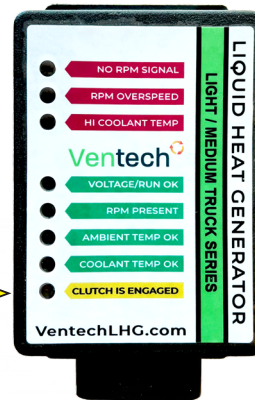
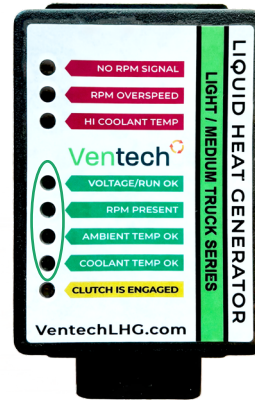

ECU LED Lights Defined

LED ON SOLID

- NO RPM SIGNAL (RPM less than 256)
- RPM OVERSPEED (LHG >6,000 / Engine >2,550)
- HI COOLANT TEMP (LHG Out Temp. >85°C / 185°F)
- VOLTAGE/RUN OK (Supply Voltage >13V)
- RPM Present (LHG >256 RPM)
- AMBIENT TEMP OK (Air Temp <10°C / 50°F)
- COOLANT TEMP OK (LHG Out Temp. <185°F / 167°F)
- CLUTCH IS ENGAGED (DC Clutch Voltage On)

LED FLASHING

Clutch is Burnishing

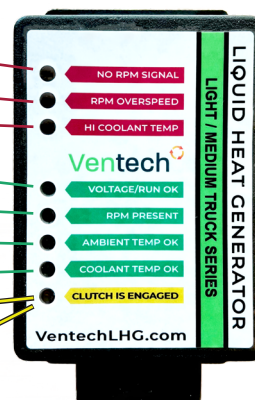

Understanding the ECU LEDs for Diagnostics

As noted above, when on solid, the red LEDs are "off-flags" that indicate a situation where the LHG will be disengaged. This does not necessarily indicate an error condition, as there are many situations when the LHG should not be engaged. For instance when the Engine RPMs are too high or when the coolant temperature does not need to be supplemented.

Below are some specific LHG ECU error conditions the LED light sequence associated with each.

These error conditions will remain showing on the ECU until the ignition is turned off, which will cause the LHG ECU to reset.

No Pulley RPM

The LHG Pulley and the LHG Clutch Rotor are independently monitored by the ECU to ensure that the LHG is running properly.

If the sensor for the Pulley fails, while the engine is running, the "NO RPM SIGNAL" LED will remain solidly on (other LEDs may be on as well) and the LHG will not engage.

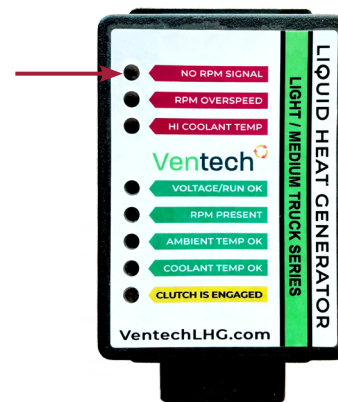

No Rotor RPM

If the Rotor RPM sensor fails, the ECU will not be able to monitor for problems with the clutch. Should this occur the ECU will disengage and/or prevent engagement of the LHG.

If the sensor for the Rotor fails, the "NO RPM SIGNAL" LED and the "RPM PRESENT" LED will alternately and repeatedly blink on and off.

Should this situation occur, Contact Ventech for assistance. The LHG will cease to produce supplemental heat until the sensor is functional.

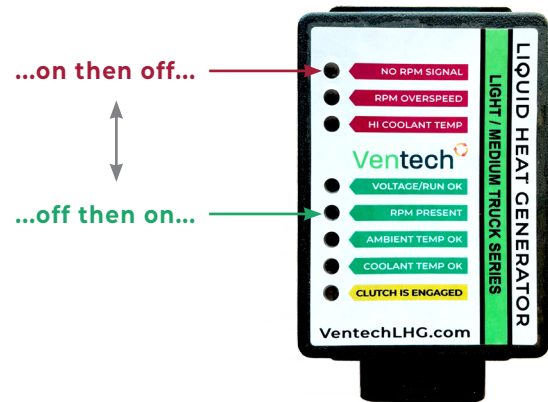

Slipping Clutch

A slipping LHG clutch prevents proper LHG operation and can lead to other problems including belt failure. For this reason, the LHG ECU is programmed to recognize and remedy clutch slippage using an automated burnishing sequence.

The ECU will attempt to correct a slipping clutch up to 5 times during continuous operation. Should this automated burnishing fail to eliminate clutch slippage, the ECU is programmed to disengage the LHG as a safety precaution.

If there is repeated clutch slippage, all of the red LEDs and the all of the green LEDs will alternately and repeatedly blink on and off

Should this situation occur, Contact Ventech for assistance. The LHG will cease to produce supplemental heat until clutch slippage is corrected.

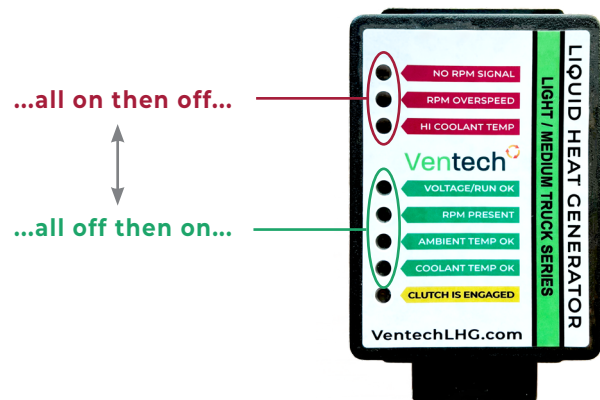

Automatic Burnishing after extended periods of Non-Operation of the Vehicle.

During vehicle storage, or other reasons for not operation of the LHG heater system over an extended period, the electromagnetic clutch plates of the LHG can become compromised by surface rust or debris collecting on the bare metal surfaces.

If ignored, the clutch performance may be compromised resulting in clutch slippage and part failure. The LHG ECU addresses this potential condition by performing a periodic burnishing routine based on the number of days that the LHG has not been operated.

This feature is fully automatic and requires no user-intervention. Automatic burnishing will occur at the intervals described below:

At the intervals shown Below, the automatic burnishing routine will start immediately after the vehicle's engine is started, irrespective of ambient air temperature.

WAIT for the burnishing routine to complete before driving the vehicle.

If the burnishing routine is interrupted before completion (engine stopped), the full burnishing routine will restart the next time the engine is started.

Interval of Non-Operation	Burnish Cycles (upon startup after interval)	Approximate time to complete
14 Days	50 Clutch Cycles	~ 1 Minute
100 Days	100 Clutch Cycles	~ 3 Minutes

Appendix B: Dash Switch Location Template

The Dash Switch Location Template can be found on the following page.

REVISION HISTORY		
REV.	DATE	DESCRIPTION
A	11/29/2022	ENGINEERING RELEASE
		ENG. GJW

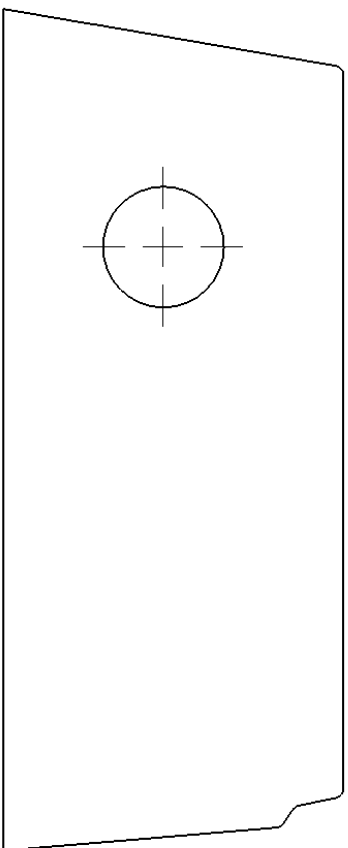

When printing this template, make sure no scaling is applied.
After printing, measure the above line for reference.

Do not use the template if the reference line does not measure as indicated.

UNITS: INCH, POUND, SECOND

NOTES:

UNLESS OTHERWISE SPECIFIED:
 ONE PLACE (X) IMPERIAL ± .06 METRIC ± .3
 TWO PLACE (XX) IMPERIAL ± .01 METRIC ± .13
 THREE PLACE (XXX) IMPERIAL ± .005 METRIC ± .03
 FOUR PLACE (XXXX) IMPERIAL ± .0005 METRIC ± .013
 ANGULAR TOLERANCE ± .5°

DO NOT SCALE DRAWING

PART NAME: Dash Switch Location Template



28389 Beck Rd.
 Unit J-2
 Wixom, MI 48393
 (248) 863-5226

MATERIAL: MATERIAL <NOT SPECIFIED>

REF.: KIT #400

MATERIAL NOTE:

WEIGHT:

DATE: 11/29/2022 DRAWN BY: GJW ENGINEER BY: GJW
 SCALE: 1:1 SHEET SIZE: A

DRAWING NUMBER: 14-0558-A0

B

B

A

A